

Modelo 11000BT

Bluetooth 11000BT Hose-End
Manual do usuário

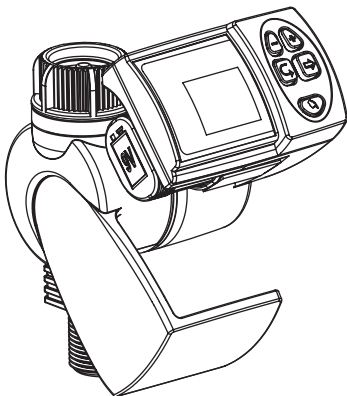

Kfar Blum Tel. 972-4-6900222
info@galconc.com | www.galconc.com

Pareamento do smartphone com os controladores Galcon

O pareamento é necessário apenas uma vez. Após o pareamento inicial, o aplicativo se sincroniza automaticamente com o controlador.

Siga estes passos para parear seu smartphone: insira as baterias apropriadas no controlador. Para instruções detalhadas, veja seu guia do usuário do controlador.

1. Baixe e instale o aplicativo Galcon BT das lojas ou escaneando o código de barras.
2. Se o aplicativo requer que você ligue o Bluetooth, digite OK para confirmar*. Uma tela de boas-vindas é apresentada.



A

GET THE APP

Favor notar!

O código de pareamento aparecerá na tela do controlador de irrigação apenas por cerca de 10 segundos

* Permitir a localização no seu Smartphone

3. Em unpaired timers [temporizadores não pareados], clique no nome do modelo do seu controlador. Se nenhum controlador for exibido, clique em Scan for timers [Procurar por temporizadores].
4. No controlador, é apresentado o ícone Bluetooth, seguido de um código de 4 dígitos.
5. Digite o código de pareamento e clique OK. Quando o pareamento estiver completado, o telefone e o controlador estarão conectados, e a tela do aplicativo será apresentada.

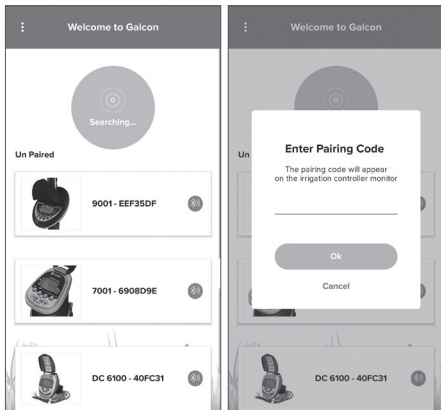

Solução de problemas

Verifique as seguintes opções:



- Certifique-se que você dá permissão para "Location Services" ao instalar o aplicativo
- Certifique-se que "Location Services" está ligado
- Vá para as opções do Bluetooth no telefone e certifique-se que o controlador está na lista dos aparelhos
 - **Se o controlador não aparece na lista, reinicie o controlador**
 - If the controller appears in the list, turn off and turn on Bluetooth on the phone
- Se o controlador está na lista, desligue e ligue o Bluetooth no telefone
- **Se o controlador aparece no aplicativo mas não pode se conectar**, tente conectar com outro telefone para identificar o problema

Para reiniciar o controlador



9001BT

Simultaneamente pressione   
por 5 segundos.



7101BT

Simultaneamente pressione   
por 5 segundos.

11000BT

Simultaneamente pressione   
por 5 segundos.

6100BT

Simultaneamente pressione   
por 5 segundos.

8000BT

Simultaneamente pressione   
por 5 segundos.

1. INTRODUÇÃO

1. Corpo do controlador.
2. Filtro interno.
3. Base do controlador.
4. Tela.
5. Botões de programação.
6. Conector masculino de torneira.
7. Compartimento da bateria.
8. Mangueira

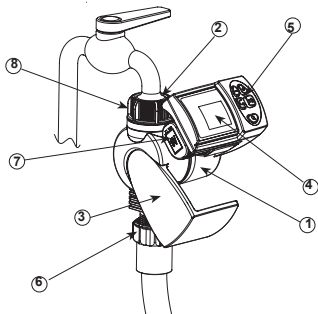

2. INSTALAÇÃO DA BATERIA

1. Com a tela do controlador posicionada de frente para você, remova a tampa do compartimento de bateria.
2. Insira a bateria de 9V no compartimento.
3. Feche o compartimento de bateria com a tampa.
4. Atenção: ao trocar a bateria, assegure-se de que o compartimento de bateria esteja seco.

Utilize apenas baterias alcalinas.

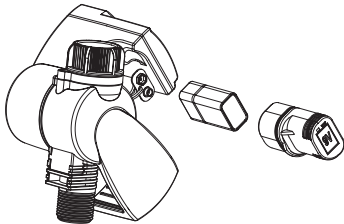

3. INSTALAÇÃO DO CONTROLADOR

4

1. Assegure-se de que o filtro esteja em seu lugar.
2. Depois, para conectar o controlador, encaixe o adaptador feminino de mangueira na torneira e gire no sentido horário, apenas com as mãos, sem utilizar ferramentas.
3. Em seguida, encaixe o conector masculino em seu sistema de irrigação.

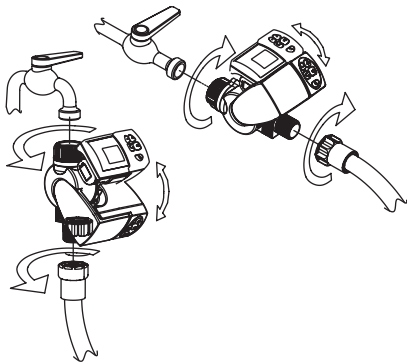

4. PROGRAMAÇÃO DE IRRIGAÇÃO

Esta seção contém um exemplo de irrigação semanal. Você pode alterar as datas exemplificadas e adaptar a programação à sua necessidade.

O controlador digital é programado com o auxílio de 4 botões:

- ⓐ Tecla 'fase de programação' - utilizada para selecionar o modo de programação desejado (por exemplo, por duração de irrigação).
- ➡ Tecla de seleção - utilizada para selecionar as opções que serão modificadas (como hora, minuto etc). Para fazer a alteração, a opção selecionada deve estar piscando na tela.
- ⊕ Tecla 'aumentar' - aumenta o número da opção selecionada (por exemplo, aumenta uma hora).
- ⊖ Tecla 'diminuir' - diminui o número da opção selecionada (por exemplo, reduz uma hora).

Se não é feito nenhum ajuste de programação, a tela do controlador sempre retorna para a tela principal (relógio).

Os dígitos na tela irão parar de piscar depois de 40 segundos.

Se a opção de ajuste selecionada parar de piscar antes de você terminar a programação, aperte a tecla  para continuar o processo.





Irrigação de emergência: Depois de inserida a bateria, caso nenhum botão seja pressionado, o relógio na tela irá piscar continuamente.

Depois de 10 minutos, o controlador irá implementar uma irrigação de 5 minutos em um ciclo de 24 horas.



AJUSTE DE HORA E DIA DA SEMANA

Ajuste do relógio

Para programar a irrigação nos dias e horários necessários, é preciso ajustar o relógio da seguinte forma:

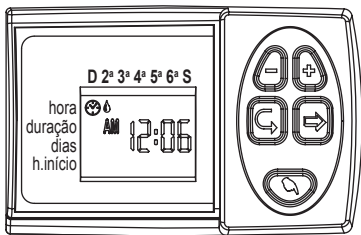
- la
1. Aperte a tecla  até que apareça o ícone .
 2. Aperte a tecla . Os dígitos das horas irão piscar. Ajuste os dígitos correspondentes à hora com os botões  e .



3. Aperte a tecla . Os dígitos dos minutos irão piscar. Ajuste os minutos com o auxílio dos botões  e .

Ajuste do dia da semana

1. Pressione a tecla ⊖ até que apareça uma gotinha piscando no topo da tela.
2. Posicione a gotinha no dia escolhido utilizando as teclas ⊕ ou ⊖.

Para um relógio 24 horas, pressione ao mesmo tempo as teclas e até que os dígitos de hora e minuto parem de piscar. Caso queira voltar para ⊕ o ⊖ sistema AM/PM, pressione novamente os mesmos botões.

PROGRAMANDO UMA IRRIGAÇÃO SEMANAL

Vamos utilizar como exemplo uma programação de irrigação de 10 minutos de duração, em três horários (às 8AM, às 1PM e às 7PM), nas terças e sextas-feiras.







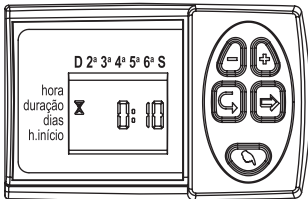

PROGRAMANDO DURAÇÃO DA IRRIGAÇÃO

1. Aperte \ominus até que apareça o símbolo Σ ao lado de 'Duração'. O dígito de hora (0) irá piscar.
2. Aperte \oplus ou \ominus para alterar a duração da irrigação.

Atenção: Depois dos primeiros 15 minutos, a duração será programada para intervalos de 15 minutos.







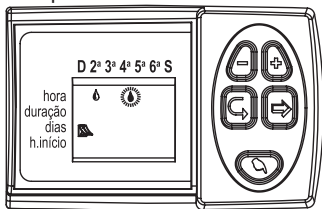



PROGRAMANDO OS DIAS DE IRRIGAÇÃO

1. Aperte . O símbolo  aparecerá ao lado da palavra 'Dias'. Se você estiver programando o controlador pela primeira vez, a palavra OFF irá piscar na tela.
2. Aperte . Uma gotinha () aparecerá embaixo da palavra 'domingo', na parte superior da tela. Utilize a tecla  para mover e posicionar a gotinha piscante embaixo do dia escolhido (no caso, terça-feira) e aperte a tecla . A gotinha embaixo de 'terça-feira' irá parar de piscar. Outra gotinha começará a piscar embaixo do dia seguinte (no caso, quarta-feira). Utilize a tecla  para mover a segunda gotinha até o segundo dia de irrigação escolhido, sexta-feira. Aperte novamente a tecla .



DEFININDO A HORA E DIA DO INÍCIO DA IRRIGAÇÃO

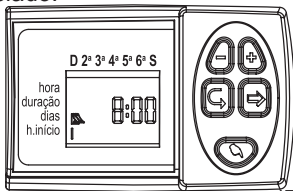

1. Aperte a tecla . A palavra START aparecerá na tela. Aperte a tecla . Os dígitos da hora começarão a piscar.
2. Utilizando as teclas  ou , ajuste a hora de início para 8AM (repare nos indicadores AM/PM). Repita essa operação para programar a segunda irrigação (START II) para a 1PM, e a terceira irrigação (START III) para as 7PM.
3. Aperte a tecla . A palavra START IV aparecerá na tela. Aperte a tecla . Os dígitos da hora começarão a piscar.
4. Aperte as teclas  ou  até que a palavra OFF apareça na tela. Assim, o início da quarta irrigação será cancelado.



OPERAÇÃO MANUAL COMPUTADORIZADA

Esta opção gerencia a válvula para o período de irrigação definido. A válvula será fechada automaticamente no final de cada irrigação. Observe que a programação original de irrigação continuará a funcionar nos períodos definidos.

Essa definição não pode ser implementada quando a tela está piscando.

Ativação: aperte a tecla . O ícone  aparecerá ao lado da palavra 'Manual', e o ícone  aparecerá embaixo da mesma.

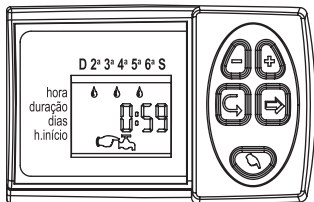

AVISO DE POUCA BATERIA

Quando a bateria estiver no final, o seguinte ícone começará a piscar: . Nesse momento, ainda restará uma quantidade de energia suficiente para uma operação com a válvula. Mas deve ser feita a troca da bateria o quanto antes.

Se a bateria não for substituída, o controlador fará ainda mais oito irrigações e depois irá parar de funcionar. A palavra "OFF" aparecerá na tela.

A programação de irrigação definida não será perdida caso a troca de bateria seja feita dentro de 30 segundos.

IRRIGAÇÃO NÃO DEFINIDA

Caso não sejam definidos os dias de irrigação, a palavra noPr aparecerá na tela (ver Programando uma Irrigação Semanal). Nesse caso, a válvula não pode ser aberta durante a operação manual computadorizada (ver Operação Manual Computadorizada).

5. MANUTENÇÃO

Remova as baterias caso o controlador não vá ser utilizado por um longo período. Remova e limpe o filtro interno de tempos em tempos. Se o filtro não for limpo de forma regular, poderá causar problemas ao controlador. Em condições normais de uso, a bateria deve durar, no mínimo, um ano.

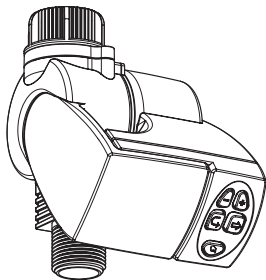

LIMITED WARRANTY CERTIFICATE

LIMITED WARRANTY CERTIFICATE AND TERMS OF SERVICE FOR "GALCON SMART PRODUCTS (GSI, CYBER RAIN, 7101BT, 9001BT, 11000BT)"

1. Galcon sells the "Galcon Smart" irrigation controllers ("the products") and provide associated product software in means of browser based software and/or mobile application software and/or client based software and/or any other software that provided with the product ("the Product Software") and certain services ("the Services") through Galcon's Web Site (www.galconc.com) and/or through any mobile phone and devices application download center and/or through self-installation software ("the Site"). This Limited Warranty Certificate and Terms of service ("these Terms") constitute a legal agreement between Galcon and the original purchaser of the Product ("the Customer"), and shall govern the Customer's access and use of the Services and the Product. By accessing the Site and/or by using the Services and/or the Product, the Customer agrees that he has read, understood, accept and agree to be bound by these Terms. If the Customer does not agree with any of the provisions of these Terms, the Customer must not access or use the Services and/or the Product.
2. Galcon shall, for a limited period of 36 months from the retail purchase date of the original (first) purchaser ("the Warranty Period"), provide limited warranty for the Product(s) and the Services, as provided for and subject to the provisions and limitations of these Terms. Without derogating from the foregoing, Galcon does not take any obligation to provide the Services (or any part therefrom) beyond the Warranty Period.
3. Galcon's Warranty for the Product and/or the Services only extends to the Customer who, upon requesting warranty service, must present Galcon with a valid and duly signed contract with Galcon (or any of its authorized dealers) together with a valid purchase receipt. Failure to produce the said documentation will result in the request for warranty being null and void.
4. Galcon warrants to the Customer that the Product shall materially conform to the description in Galcon's documentation and shall be free from defects in material and workmanship. Accordingly, Customer's sole and exclusive remedy under this warranty is the repair or – to Galcon's sole discretion – the replacement of the Product or any parts according to the terms of this Warranty, and no other remedy shall be available. Therefore, if - within the Warranty Period - the Product is proven to be defective by reason of faulty workmanship or materials by Galcon, Galcon undertakes, with reasonable promptness, to have the defective Product (or any part/s thereof) repaired, or at Galcon's discretion, replaced; All subject to the terms and conditions of these Terms.

5. Galcon's warranty for the Product and/or the Services and/or otherwise, shall not apply to any of the following: (i) any conduct (by act or omission) not by Galcon, including any misuse/abuse of any Product and/or the Services (or part/s thereof), and/or any failure to install and/or use any Product in full compliance with Galcon's instructions; (ii) other systems/components/devices/technologies and/or the integration/interface thereof with any Product.; (iii) any part/component which has been included/installed in any Product not at Galcon's approval and/or other than by Galcon; (iv) any actual or attempted change/repair/interference of/with any Product (including any use/handling of, and/or interference/dealing with, any code of any software included/used in the Product) other than by Galcon; (v) any data/information/content which has been inserted/included in a Product and/or the Services; (vi) malfunction or damage resulting from accidents, which occur during transit and/or handling, and/or malfunction or damage due to fire, earthquake, flood, lightning and/or any other external disaster; (vii) unforeseen accidents, wear and tear, or any other external factors beyond Galcon's reasonable control, or to any Product installed, repaired, adjusted, rebuilt, modified, changed or converted by any person (including the Customer) other than Galcon;
6. In addition and without derogating from the provisions of these Terms, Galcon's warranty and the Customer's rights to use/access the Services and/or the Site, is conditioned upon the all of following Customer's undertakings taking place: (i) Customer's operating and maintaining the Product and/or the Services in accordance with Galcon's instructions; (ii) Customer's not being in default of any payment obligation to the Galcon (or its authorized dealer, as relevant); (iii) the Customer shall not license, sell, rent, lease, transfer, assign, distribute, host, or otherwise commercially exploit the Services; (iv) the Customer shall not to modify, make derivative works of, disassemble, reverse compile, or reverse engineer any part of the Services; (v) the Customer shall not to access the Services and/or the Site in order to build a similar or competitive service; (vi) except as expressly stated herein, no part of the Services may be copied, reproduced, distributed, republished, downloaded, displayed, posted, or transmitted in any form or by any means; (vii) the Customer shall not upload, transmit, or distribute any computer viruses, worms, or any software intended to damage or alter a computer or communication network, computer, handheld mobile device, data, the Services, the Product, the Product Software, or any other system, device or property; (viii) the Customer shall not interfere with, disrupt, or attempt to gain unauthorized access to, the Site, the servers or networks connected to the Services or violate the

- regulations, policies, or procedures of such networks; (ix) the Customer shall not access (or attempt to access) any of the Services by means other than through the interface that is provided by Galcon; (x) the Customer shall not remove, obscure or alter any proprietary rights notices (including copyrights and trademark notices) which may be contained in or displayed in connection with the Services; (xi) any use or access by anyone under the age of 18 is prohibited.
7. Subject to these Terms, as well as additional guidelines, terms, or rules referred to in this document and incorporated by reference into these Terms, Galcon grants the Customer a non-transferable, non-exclusive, limited right (without the right to sublicense) to use the Services for the Warranty Period only and solely for the purpose of controlling and monitoring the Product installed on Customer's property.
 8. Galcon does not give any warranty or guarantee whatsoever in respect of any Product or Services (or any part/s thereof) which has not been manufactured and distributed by Galcon and which has not been purchased from Galcon or any of its authorized dealers, whether such products are branded with any trademarks similar to any trademark belonging to or used by Galcon.
 9. After replacement or repair of the Product, the Warranty for the new or repaired Product shall be valid only for the non-expired period of the original Warranty Period. Any defective Products or part/s, which has been replaced, shall become Galcon's property.
 10. Galcon reserves the right to charge the Customer if any warranty service is requested and carried out but no fault is found in the Product or if such defect/fault is not under Galcon's Warranty.
 11. Notwithstanding anything to the contrary, Galcon shall not be responsible and/or liable, under any circumstances and in any way, for any loss, damage, costs, expenses, expenditures, responsibility and/or liability (including of Customer and/or any third party) – including (without limitation) direct and/or indirect (including incidental and/or special and/or consequential), however arising, including in respect of damages to or loss of property and/or equipment, loss of profit, loss of use, loss of revenue or damages to business or reputation, whether or not based on breach of contract, tort (including negligence), product liability or otherwise - arising from the performance or non-performance of any aspect of the Services and/or the Product and/or access to Site or any part thereof; All of the above, whether or not Galcon and/or the Customer shall have been made aware of the possibility of such loss.

- SS
12. In any event, any liability which Galcon may have in connection with the Product and/or the Services and/or access to Site and/or these Terms, including (without limitation) in connection with and/or resulting from the Product (or any part thereof) and the use thereof and/or the Services, shall be limited to a total amount (for all damages, claims and causes of action in the aggregate) equal to the consideration actually received by Galcon from the Customer for the Product. The limitations shall apply whether the liability is based on contract, tort, strict liability or any other theory.
- a
13. The Customer warrants and agrees, that Galcon owns and shall continue to own all title, rights and other interests (including all intellectual property rights) in connection with the Product, the Site, the Services, and all content available through the Site, including any and all trademarks, service marks, and logos contained therein. The provision of the Product, the Product Software, and/or the Services does not transfer to the Customer or any third party any rights, title, or interest in or to such intellectual property rights. The Customer may not copy, further develop, reproduce, republish, modify, alter, download, post, broadcast, transmit, or otherwise any material made available in the Site or the Services.
- t
- y
- rs,
- ct
14. The customer creates data when he uses the service that is related to programming the product. The customer hereby provides Galcon with a license to use, upload, display, copy, manipulate, and store any data that the Customer shall create/insert when he uses the Services and/or the Product. The customer acknowledges and agrees that he shall always remain solely responsible and liable for its said data.
- y.
- 1
15. Galcon has no obligation to accept, display, review or maintain any Customer content. Moreover, Galcon reserves the right to edit, delete, distort or move Customer's content from the Site and/or Services without notice for any reason at any time. Any submitted Customer's content shall not be considered confidential and may be disseminated by Galcon without any compensation to the Customer. Customer's content may be available to the public, and the Customer should have no expectation of privacy with respect to its content. The Customer acknowledge that he provide his personal information at its own risk.
- a,
16. The Customer warrants and agrees, that the Provision of Services is dependent upon the receipt of information from a variety of third party sources, including with respect to weather data and therefore cannot guarantee the accuracy of such information.
- te

The site and services are provided on an AS IS and on available basis without warranties of any kind from Galcon. The use of the Site, the Product and/or the Services is at the Customer sole risk.

17. Galcon is not responsible for any problems or technical malfunction of any telephone network or lines, wireless network of any kind (Wifi, Cellular, Bluetooth or other) computer online systems, servers or providers, computer equipment, or software due to technical problems or traffic congestion on the internet or on the Services and/or the Site. Under no circumstances shall Galcon be responsible for any loss or damage resulting from use of the Product, Site and/or the Services.
18. Galcon may suspend or terminate the Services and/or the Customer's account at any time upon written notice to the Customer that the Customer breaches these Terms and, to the extent that the breach can be cured, the Customer does not cure that breach within 14 (fourteen) days.
19. This Warranty and the remedies set forth herein are exclusive and in lieu of all other warranties, remedies and conditions, whether oral, written, statutory, express or implied. **GALCON SPECIFICALLY DISCLAIMS ANY AND ALL STATUTORY OR IMPLIED WARRANTIES, INCLUDING, WITHOUT LIMITATION, WARRANTIES OF MERCHANTABILITY AND FITNESS FOR A PARTICULAR PURPOSE AND WARRANTIES AGAINST HIDDEN OR LATENT DEFECTS.**
20. The Customer shall be solely responsible for the selection, use, efficiency and suitability of the Product(s).
21. The provisions of this Limited Warranty Certificate shall be interpreted and governed, solely and exclusively, pursuant to the laws of the State of Israel, and no other law shall apply. Any and all legal actions shall be litigated within the jurisdiction of the courts of Israel, and no other jurisdiction shall apply. Customer waive any objection to such jurisdiction and venue on the basis of it being an inconvenient forum.

GDB8CP.01



Kfar Blum Tel. 972-4-6900222

info@galconc.com | www.galconc.com