

# Electrically Operated Advanced Computerized Irrigation Controller Installation and Operating Manual

**Controller Model 800248 –  
Operating 1 to 24 valves + Main Valve or Pump**

**Controller Model 800244 –  
Operating 1 to 4 valves + Main Valve or Pump**

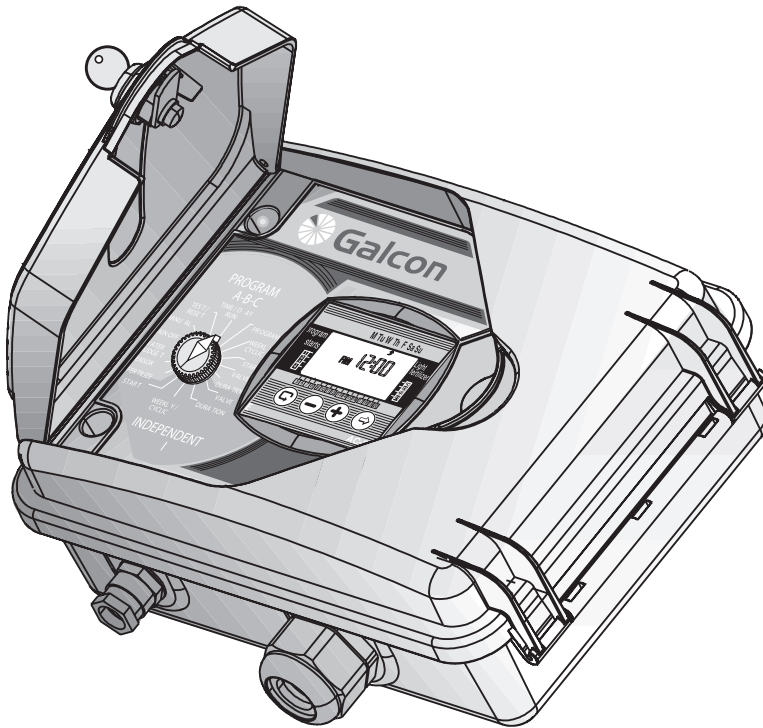

Kfar-Blum 1215000, Tel: 972-4-690-0222 Fax: 972-4-6902727 E-mail: info@galconc.com, www.galconc.com

## **Controller Features:**

- Control the operation of 1 to 24 valves + main valve or pump
- Operating 24 VAC electrical valves
- Sensor input
- Weekly or cyclical irrigation programming for a number of values
- Independent weekly or cyclical irrigation programming for individual valves
- Fertilization programming of individual valves
- Programming for garden lighting system
- Optional percentage modification of irrigation duration
- Irrigation duration from 1 minute up to 9 hours
- Irrigation frequency from once daily to once every 30 days
- Computerized manual operation of individual valves or valve groups
- Detection of short circuits; short-circuited valve cutoff with visual warning
- Memory backup of program for 20 years (batteries unnecessary)
- Clock backup with 9V battery (not included)
- Galcon's warranty and service

**Input power: AC 230V 50Hz**

**Output power: 24V 20VA**

**Environmental conditions: -33°C - 65°C, 2000 m altitude  
IP54**

## CONTENTS

### **Installation Preparation**

- 1. Adjusting irrigation controller to valves 5
- 2. Manual-Mechanical Operation 5

### **Installation and Wiring Instructions 6**

- 1. Controller installation 7
- 2. Adding to or Replacement of 4-Valve Model 8
- 3. Connecting solenoid wires 9
- 4. Safety instructions 12
- 5. Connecting controller to power source 13
- 6. Sensor connection 14

### **Programming the Irrigation Controller**

- 1. General Information 15
- 2. Setting current time and day of the week 16

### **Programming of valve-group irrigation 17**

- 1. Programming weekly irrigation 18
- 2. Programming cyclic irrigation 20
- 3. Selecting valves for weekly/cyclic programming 21
- 4. Setting irrigation duration times for weekly/cyclical programming 22

## **Programming controller for Individual valve – Independent Program I**

- |                                                               |    |
|---------------------------------------------------------------|----|
| 1. Valve selection for Independent Program I                  | 23 |
| 2. Setting irrigation duration time for Independent Program I | 24 |
| 3. Irrigation by day of the week                              | 25 |
| 4. Selecting cyclic irrigation schedule                       | 27 |

## **Advanced Controller Programming for Valve-Groups and Independent Program I**

- |                                                                      |    |
|----------------------------------------------------------------------|----|
| 1. Fertilization supplement                                          | 28 |
| 2. Fitting valve to sensor                                           | 29 |
| 3. Garden lighting system                                            | 30 |
| 4. Irrigation duration extended or shortened according to percentage | 31 |
| 5. Suspension                                                        | 32 |
| 6. Computerized manual operation                                     | 33 |
| 7. Testing                                                           | 34 |
| 8. Program RESET                                                     | 34 |

## **Maintenance**

- |                                         |    |
|-----------------------------------------|----|
| 1. Low battery warning                  | 35 |
| 2. Missing AC power                     | 35 |
| 3. Filter                               | 35 |
| 4. Water pressure                       | 35 |
| 5. Troubleshooting detection and repair | 36 |

## **Additional Accessories 37**

## 1. Adjusting the Irrigation Controller to the Valves

The irrigation controller is designed to operate standard electrical valves of up to 24VAC 2.2 W. The valves are not supplied with the controller.

1. Close the main water valve.
2. Install valves in the irrigation system.

**ATTENTION !**

**Direct water flow according to the arrow above entrance pipe (A). (Illustration 1)**

The main electrical valve may be installed at the entrance to the irrigation system. The main valve will open automatically when one of the valves is open, and will automatically close with the closing of the last valve.

The main valve is shown on the display panel and on the connection toolbar by the letter M.

It is not necessary to program the main valve.

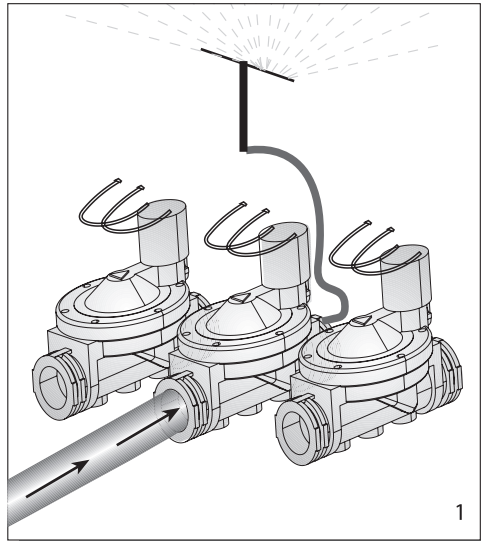

1

## 2. Mechanical Manual Operation

The irrigation valves may be opened/closed unrelated to the operation of the controller. This mode is useful when irrigation is necessary immediately, and either a lock of time or knowledge makes operating the irrigation controller impossible.

The manual operating handle is located under the solenoid.

1. To open the valve turn the handle counter-clockwise (illustrated in 2)
  2. To close the valve turn the handle clockwise (illustrated in 1)
- When the electricity is turned on the valve cannot be closed manually.
  - To operate a valve with the controller, the manually operated handle must be in a closed position (1).

**ATTENTION !**

**If there is a main manual valve, this should also be opened manually**

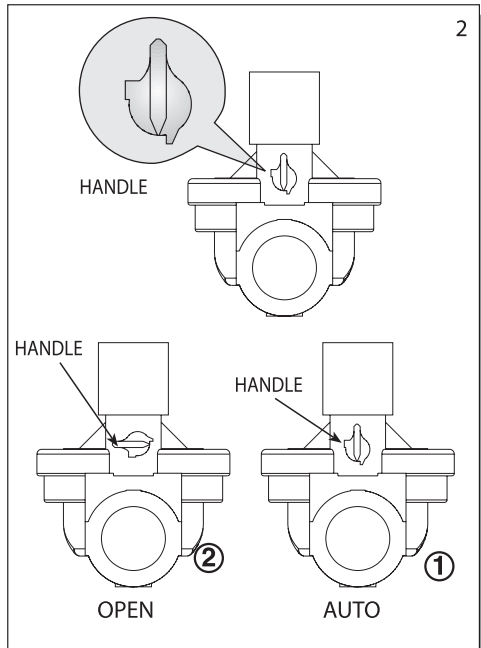

2

**ATTENTION !**  
It is recommended to position controller in an accessible place and at eye-level.

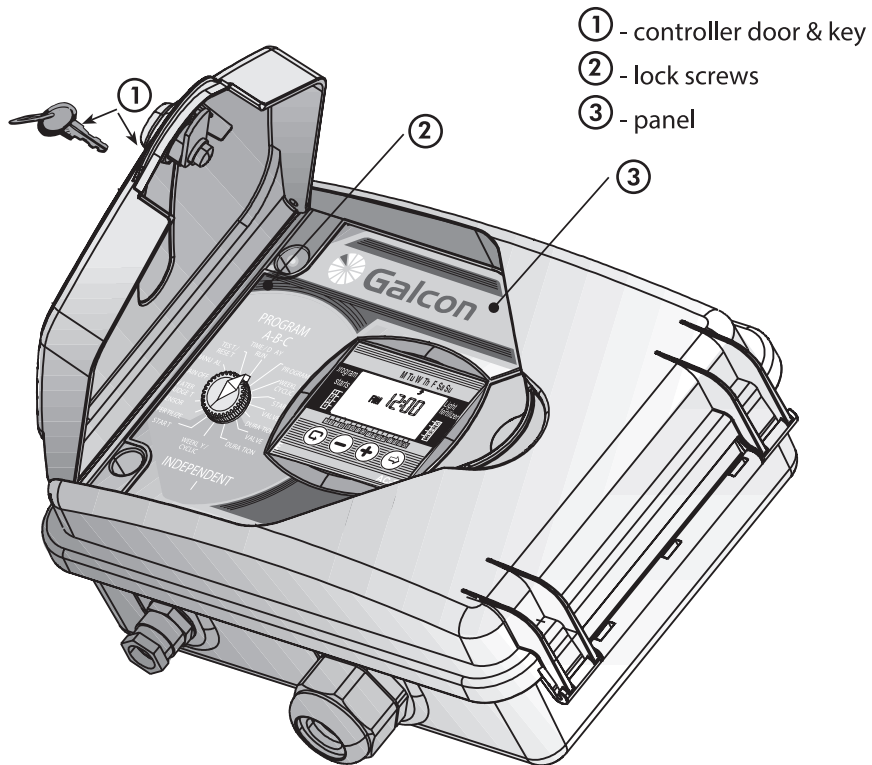

- Open the controller door with the attached key.
- To get to the connector board, release the lock screws on the left side of the controller beneath the main cover and open the panel.

## 1. Controller Installation

Install the controller on the wall or in a controller cabinet by mounting it with two screws at the designated holes (2). Use the included plugs to cover these screws.

**Place a 9V Alkaline Non-rechargeable battery in the appropriate place.**

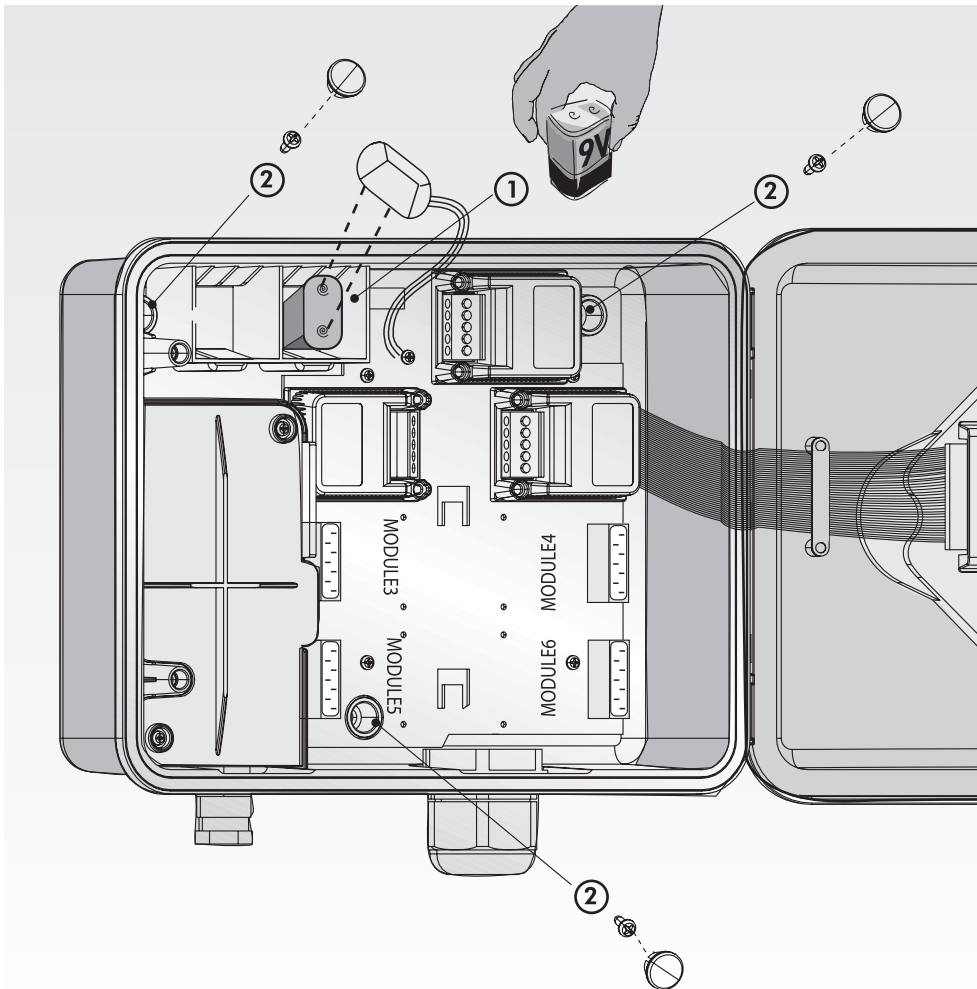

## 2. Adding or Replacing 4 Valve Module

**Attention: Modules may be added or replaced only in the AC-800248 Model**

In order to add or replace a 4 valve module the following procedures must be performed:

1. Turn selector to Testing mode.
  2. Turn off electricity.
  3. Wait one minute.
  4. Remove battery.
  5. With a "cross-head" screwdriver, open screws on front of module.
  6. Add or replace module with a push or pull as shown in illustration.
  7. Fasten screws at front of module.
  8. Replace battery in position.
  9. Turn on electricity.
- \* The number of valves the controller will now operate will appear on the LCD display.  
 \* The current time must be set.

**THE PROGRAMS INSTALLED IN THE CONTROLLER WILL BE STORED DESPITE CUTOFF FROM ELECTRICITY VOLTAGE (MEMORY OF 20 YEARS!)**

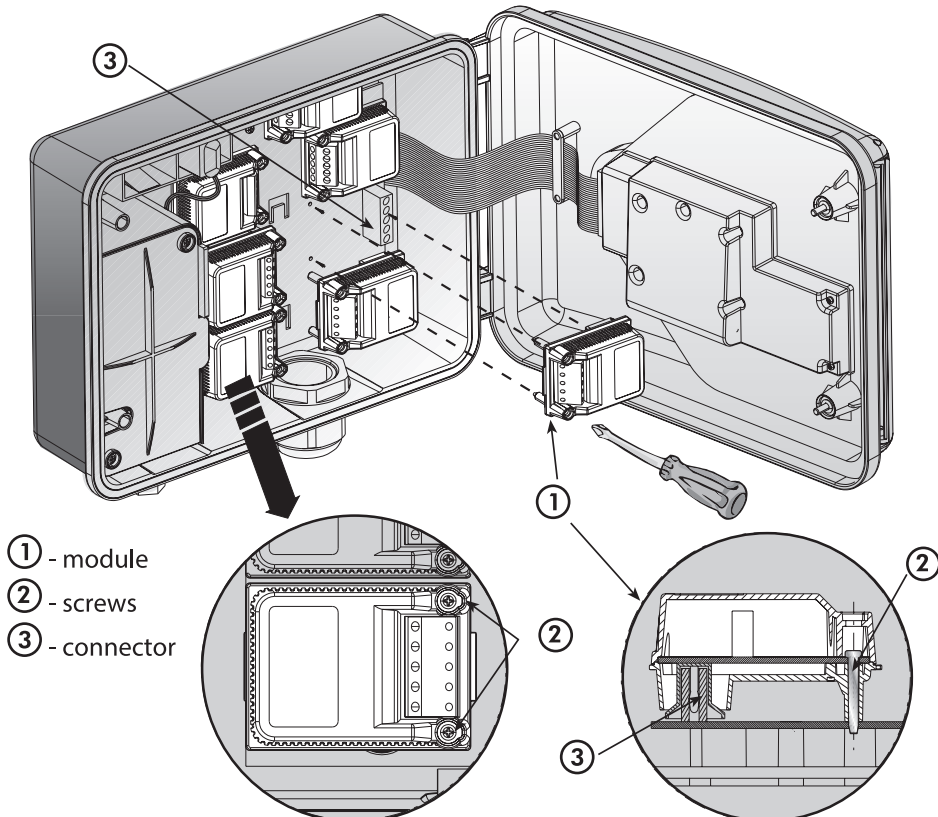

**THE PROGRAMS INSTALLED IN THE CONTROLLER WILL BE STORED DESPITE CUTOFF FROM ELECTRICITY VOLTAGE (MEMORY OF 20 YEARS!)**

### 3. Connecting Solenoid Wires

#### General

Two wires identical in color and polarity are connected to each solenoid. One wire (either one) must connect to the desired valve in module. The second wire must be connected to joint C point in model. Distance between controller and valves usually are longer than solenoid wires. The valve control cable may be used to connect wires. The valve control cable connects the controller to solenoid connector box.

#### Valve Control Cable Features

- Valve control cable transmits only 24 volt
- Number of wires in valve control cable must be at least the same number of selected valves, in addition to two – one for master valve and one for joint wire. To facilitate wiring, it is recommended to use differently colored wires.
- It is recommended to use cable with larger number of wires to allow for additional valve connections in future, or in order to substitute faulty wire.
- Minimum width of valve control cable wires must be 0.5 mm<sup>2</sup>. If valves are at a distance of more than 100 meters from controller, consultation with Galcon is necessary in order to set correct width.
- Valve control cable must be fixed on wall with nail clasps or alternately underground in properly protective pipe.
- It is recommended not to use a cable composed of several connected parts. If necessary, the cable parts should be connected with protective connection box.
- Connection of valve control cable to valves must be made with electrical connectors in properly protective connector box (not included). It is recommended at the number if connection points in designated box exceed number of valves.

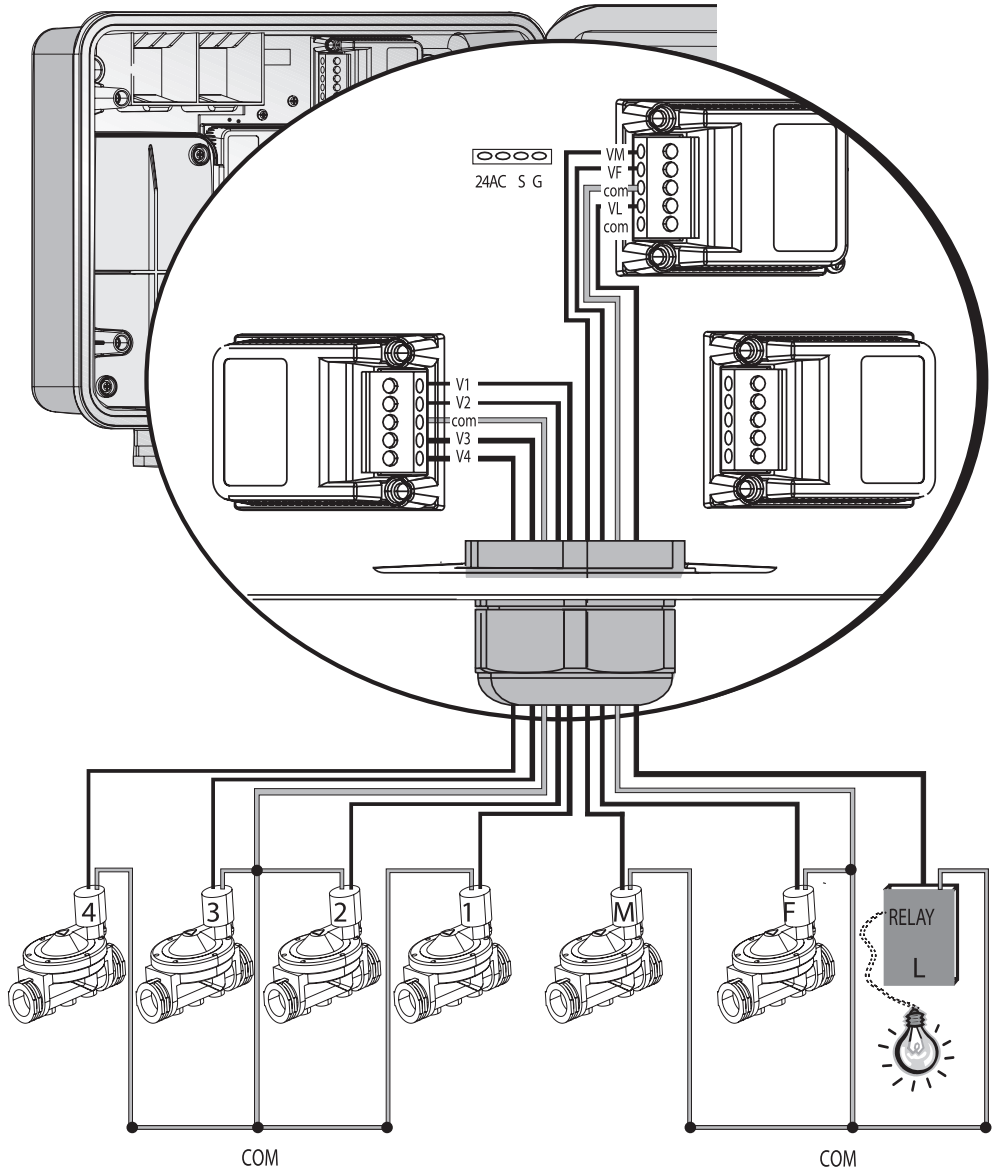

## Connecting Extension cable

1. Open the controller panel by opening the screws at the left side of the controller. (See diagram)
2. Insert the cable through the large cable protector (4).  
Connect the wires to the terminal block. Every module has a "com" connection point.  
Note the colors and positions of the connecting wires for your reference.
3. Connect the free end of the cable to the connection box adjacent to the valves, according to the color and number key you marked down previously.
4. Connect the valves to the connection box.

- ① - Connection box
- ② - Extension cable
- ③ - Valves
- ④ - Cable protector
- ⑤ - Cable tie

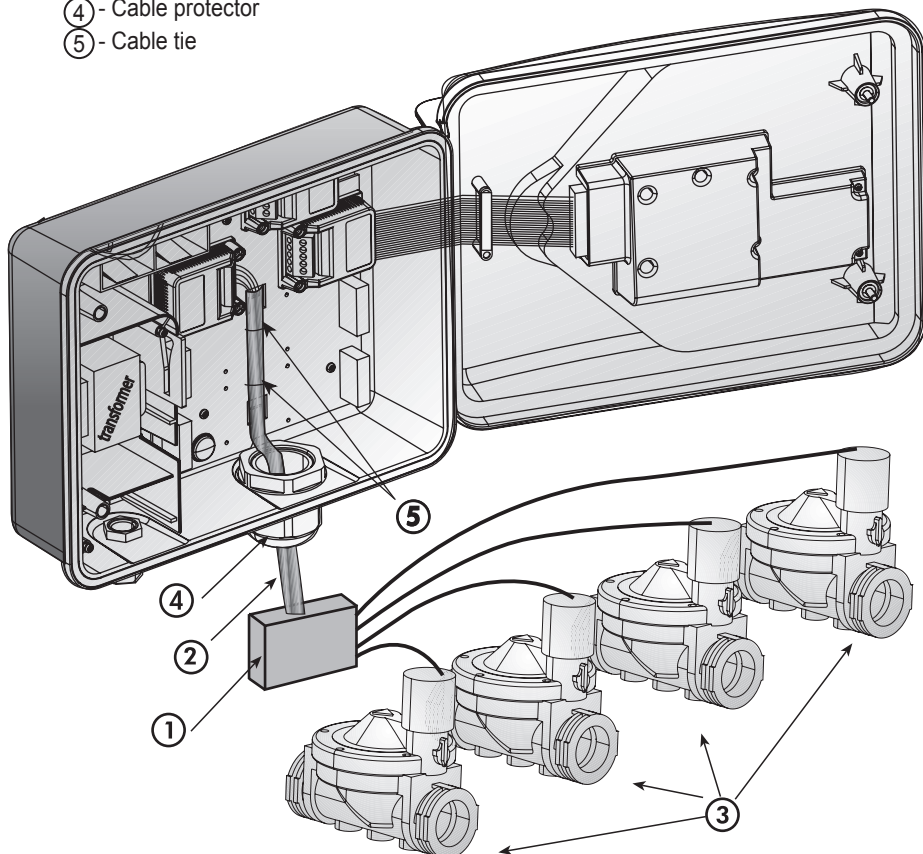

## 4. Safety instructions

**WARNING!**

Use only included built in transformer.

Any connection made between the irrigation controller to power source or any other electrical apparatus other than irrigation valves must installed by a licensed electrician.

**WARNING!**

In case the controller is supplied with a power supply cable connected to it, the controller is for indoor installations only!

In order to use the controller for outdoor installation, a licensed electrician must disconnect the power supply cable, and connect the controller according to the instruction below.

If plug doesn't comply with local regulation, plug must be replaced by suitable plug by licensed electrician.

**WARNING!**

Solenoid control by 24VAC is considered hazardous live in wet locations.

## 5. Connecting the Controller to power source

If using an internal transformer, minimal wire diameter must be 0.7 mm<sup>2</sup>. Check with standard measuring equipment that there is no voltage in the electric circuit.

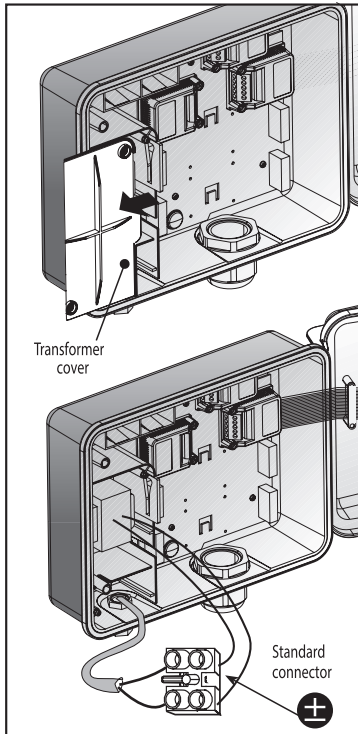

1. Open the controller panel by opening the screws at the left side on the controller.
2. Remove the high voltage cover and screws.
3. Thread the electrical cable through the small cable protector at the left.
4. Tighten the cable protector around the cable.
5. Connect the wires to the connector (included), the connector can be pulled out for an easy connection.
6. Close the high voltage cover with the screws.
7. Close the controller panel.

### Notice!

It is necessary to connect a two-polar switch between the 110VAC/230VAC electrical supply and the controller.

The 110 VAC/230 VAC supply point, the circuit and connection to the transformer must be performed according to "Field Electrical Regulations" by a licensed electrician who is accredited with a license according to the Electrical Bill and security requirements.

Mark the switch with a sticker "Disconnecting switch for controller".

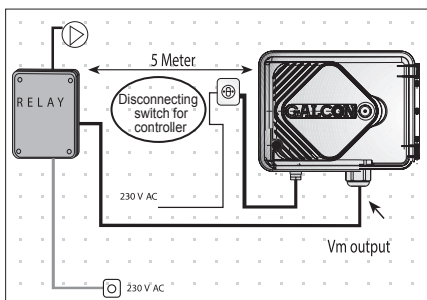

**ATTENTION!**

**DO NOT CONNECT THE CONTROLLER TO A VOLATGE POINT USED FOR OTHET ELECTRICAL EQUIPMENT.**

**IF THE CONTROLLER IS CONNECTED TO RELAY STATION OF ANY KIND IT MUST BE DISTANCED BY A MINIMUM OF 5 METERS.**

### 6. Sensor Connection (Optional)

Connect the wires of the sensor to the top connection toolbar, marked SNSR (G + S) .  
The polarity of the connections is insignificant.

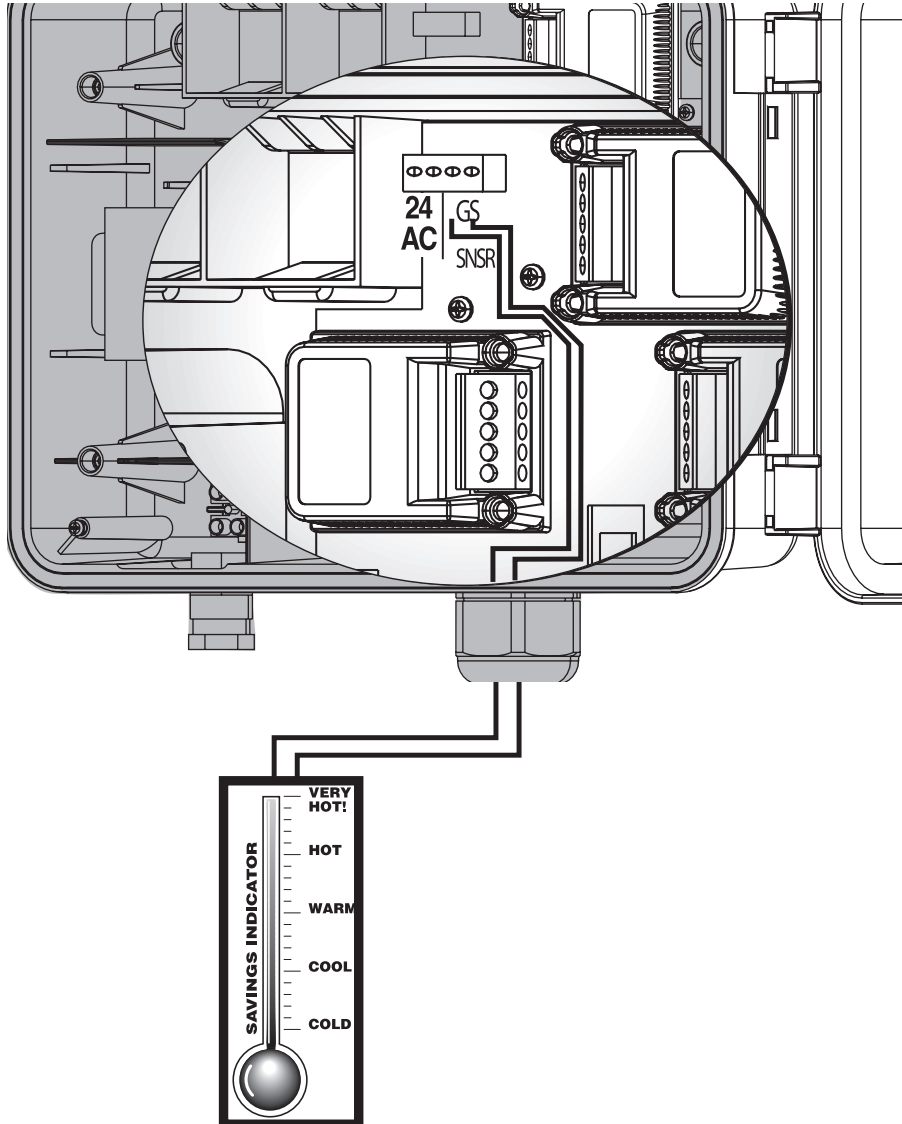

## 1. General Information

The AC-24 controller has two types of irrigation programming:

- Valve Group irrigation programming
- Independent valve irrigation programming
- Garden lighting may be operated
- Fertilization programming for each valve may be operated

### **Irrigation Programming for Valve Group:**

Three programs (A,B,C) may be programmed.

For each separate program, irrigation days must be selected for all of the valves connected to the program group. A starting time is set for the first valve, and duration of irrigation for each separate valve. The valves will open sequentially, according to the sequential number marked on the display – when the first valve closes the second will open, and so forth. At one given moment, only one valve will be open. If the programs A, B, and C have been programmed to overlap in irrigation time, Program A will open first, and only after the program has ended will Program B begin, and, finally, Program C.

### **Independent Program I**

In this program the irrigation schedule is defined for each individual valve. Firstly the desired valve must be selected and afterwards the irrigation programming may continue: setting irrigation duration, days of irrigation, or irrigation cycle, and starting time for the designated valve.

### **General Information**

Programming the controller with a 16-position selector and 4 buttons.

- ⊞ Press Button to pass between the fields in different positions of the selector.
- ↔ Press Button to select the data to be modified (e.g. hour, minute, etc.).
- ⊕ Press Button to increase the value of the selected data (e.g. adding an hour)
- ⊖ Press Button to decrease the value of the selected data (e.g. decreasing an hour)

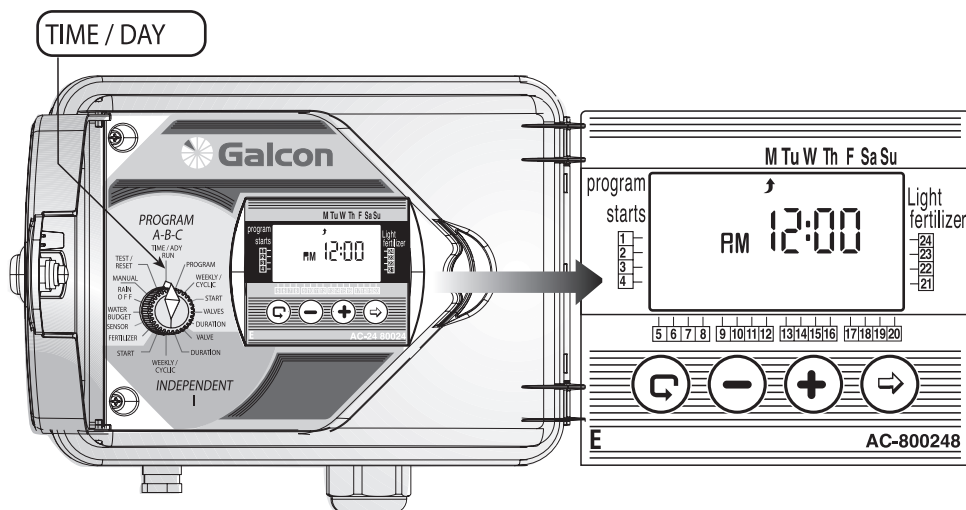

## 2. Setting the Current Time and Day of the Week

In order for the irrigation controller to operate the irrigation system at the desired times, the current time and current date must first be set.

- Set the selector to clock position, press on . The hour digits will blink. Set the current time using the and as necessary. (Note the AM and PM designations).
- Press on . The minute digits will now blink. Set the current minute timing by using the and as necessary.
- Press on . A blinking arrow will appear at the top of the display panel. Position the arrow in line with the current day by using the and as necessary.
- It is possible to alternate to a 24 hour (European) time format by pressing simultaneously on and after the blinking ends. An additional pressing on these buttons will switch the format back to the AM/PM format.
- After this programming, with the selector at the clock mode and an operating valve, a drop will appear on the screen in line with the open valve, along with remaining irrigation time.

**The selector should be returned to the TIME/DAY mode following modification or ending of the program**

**As stated, the controller allows for two types of valve programming:**

1. Programs A, B, and C – programming designated for a group of valves.
2. Independent Program I – separate programming for each individual valve independently. For this program, turn to page 21.

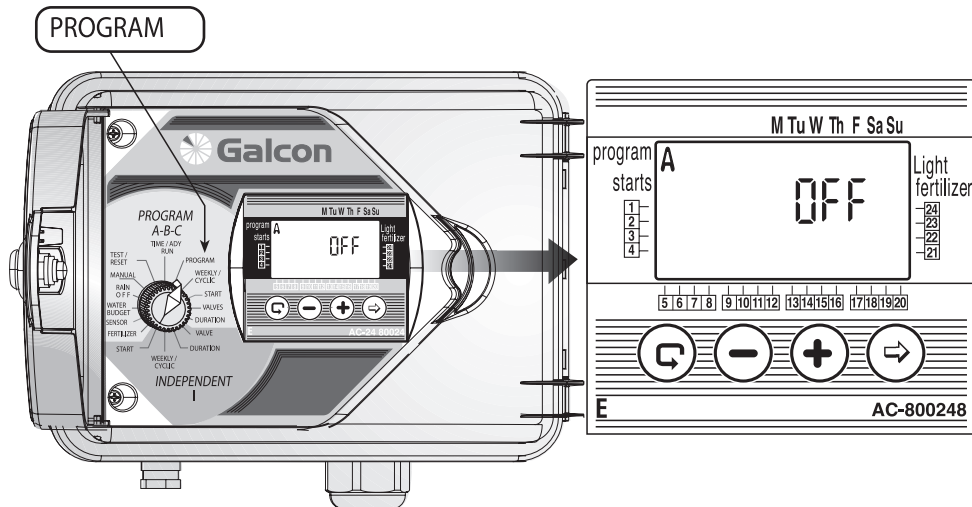

**Controller Programming for a Valve Group (A,B, and C)**

- To select Program A, or B, or C, or to select a Lighting Program (for the lighting program see page 28), turn selector to the Program Choice Mode.
- One of the three programs will appear on the display panel – press on G until the desired program appears, for example A. (The Light symbol for the lighting program will also appear, see page 28).
- In order to select the program press on →. The word OFF will begin to blink. Pressing the + button will make the button blink. Program A has been selected.
- By pressing the - button the program will be closed (OFF). The program is no longer operating.
- Note that at this stage continue with weekly/cyclical programming (Pages 16/18).

**The selector should be returned to the TIME/DAY mode following modification or ending of the program.**

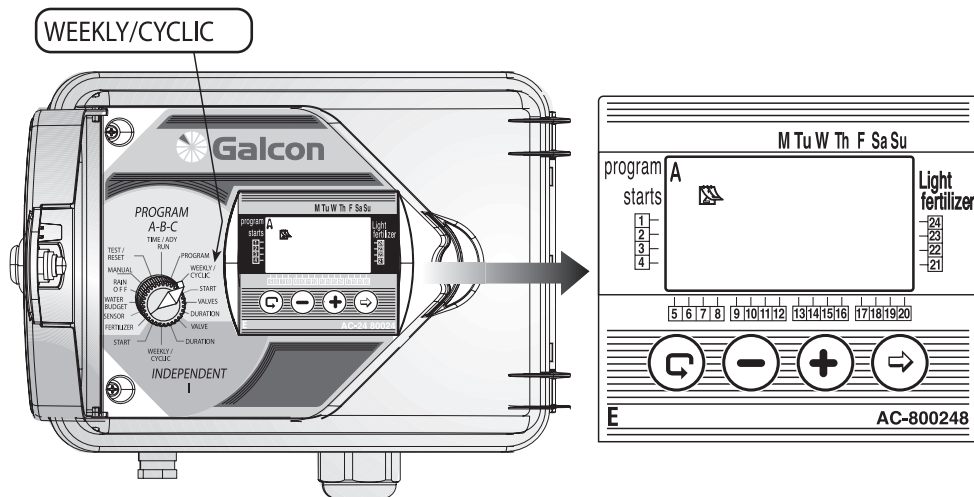

## 1. Weekly Programming





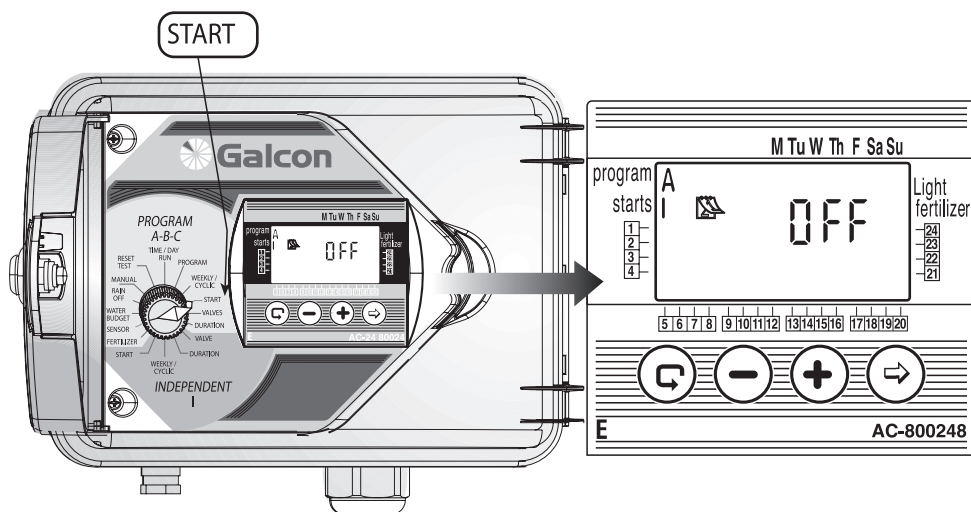



- In this operation the days of the week for irrigation will be set for valves connected to the designated program.
- Tune the selector to the **Irrigation Days/Cycle** (Programs A, B, and C).
- Press on and select weekly programming .
- Press on . At the top of the display panel a blinking arrow will appear under Sunday. If you select to set Sunday as an irrigation day press . The arrow under Sunday will remain set and stop blinking while the arrow under Monday will begin to blink. If you do not select to set Sunday as an irrigation day press . and the arrow will disappear and an arrow under Monday will begin blinking, and so forth.

**The selector should be returned to the TIME/DAY mode following modification or ending of the program.**



## Programming Start Times for Weekly Irrigation

In this operation up to four daily starting times may be set for all of the programs (A, B and C). Each start time operates firstly the designated main valve for the program and sequentially the remaining valves will open.





- Set selector to **IRRIGATION STARTER** (A, B or C programs). **START 1** will appear on display panel, Weekly Program symbol , OFF or the last programmed start time.
- Press on . The data will blink on and off.
- Press  or  to set the desired start time. (Pay attention to AM and PM settings). If desired, repeat steps for START 2, 3 and 4. To cancel a particular start time, designate with  and press . Time will blink. Press on  or  until OFF appears on display panel.
- For additional programs select new program (e.g. B), then repeat the above steps. To continue programming see page 19 – Valve Selection.

**The selector should be returned to the TIME/DAY mode following modification or ending of the program.**

## 2. Cyclic Irrigation Programming

The controller is programmed to operate the selected program at set cyclic times. The cycle can be set from one day up to 30 days. The cyclic time will be identical for all of the valves attributed to the selected program.









### Cycle Time Selection

- Turn selector to **WEEKLY / CYCLIC** mode (in Programs A, B and C)
- Press on  until  symbol and **DAYS 1** appear (Irrigation cycle of 1 day).
- Press on . **DAYS 1** blinks.
- Set cycle time using  or  as necessary up to DAYS 30.

### Starting Irrigation Cycle for Cyclic Programming

In this operation the time and day for starting cyclic irrigation of the first valve is set (in cyclic programming there is only one start time). All of the valves attributed to the designated program will open in sequential order. As the first valve closes, the second will open and so forth.

The number of days preceding the start of the program must be set. **0 DAYS** - irrigation will start as of that day, **1 DAYS** - irrigation will start the following day and so forth. Days preceding start of cycle irrigation may be up to 14 days. .

- Turn selector to **START** mode (Programs A, B and C). **STARTS I**, and the last displayed starting time or **OFF** will appear on display panel.
- Press on . Hour digits will blink. Set the desired starting time using the  and  as necessary.
- Press on . Minute digits will blink. Set the desired minutes for the starting time using the  and  as necessary.
- Press on  until the number 1 and the word **DAYS** appear on display panel. Set number of days preceding start of cycle with  or  as necessary.

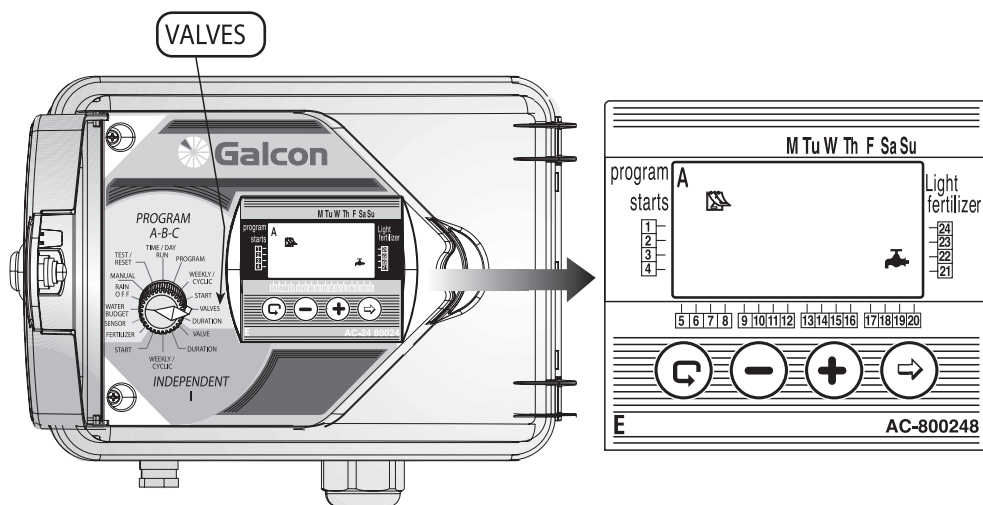

### 3. Selecting valve/valves for a valve group (A, B or C)

In this operation designate which valves are to be attributed to the selected program. One to 24 valves may be selected for a particular program.

**ATTENTION!**  
**Each individual valve may be allocated to only one of the 4 programs (a, b, c, i)**

- Set selector to VALVE SELECTION (Programs A, B, C). Selected program will appear on display panel. Mark valve , and  next to valves previously selected.
- Press on . First available valve will blink.
- Press on to select valve. Selected valve symbol will stop blinking. Sequential valve will begin blinking, and so forth.
- In order not to select valve press . Valve will disappear. Sequential valve will begin to blink, and so forth.
- Press in order to view all available valves in controller (including those selected for designated program).

**The selector should be returned to the TIME/DAY mode following modification or ending of the program.**

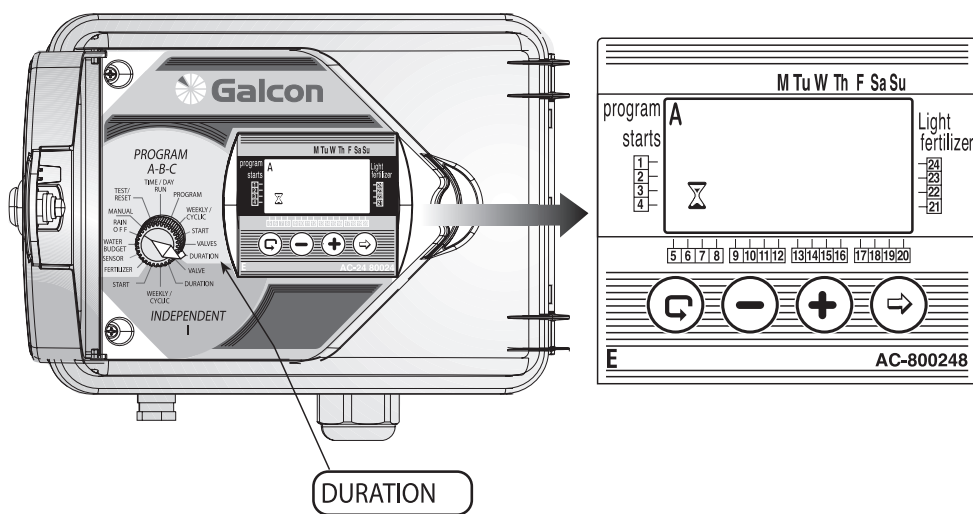

## 4. Setting Irrigation Duration ⌚ for each Valve

In this operation the controller is programmed to operate the selected program at set cyclic times. The cycle can be set from one day up to 30 days. The cyclic time will be identical for all of the valves attributed to the selected program.

### Cycle Time Selection

- Turn selector to Irrigation **Days/Cycle** mode (in Programs A, B and C)
- On the display panel the symbol of the current program will appear, along with the type of program (weekly/cyclic), duration symbol ⌚ and valve symbol □ in line with the valve you have designated.
- Press on ⏪. ⏩ until ⏪ symbol and caption DAYS 1 (Irrigation cycle of 1 day) appear.
- Press on ⏪. DAYS 1 blinks.
- Set cycle time using ⏩ or ⏪ as necessary up to DAYS 14 (14 days).

**ATTENTION!**  
**Irrigation duration set at 0:00 will not be opened.**

**The selector should be returned to the TIME/DAY mode following modification or ending of the program.**

# Programming controller for Individual valve - Independent Program I

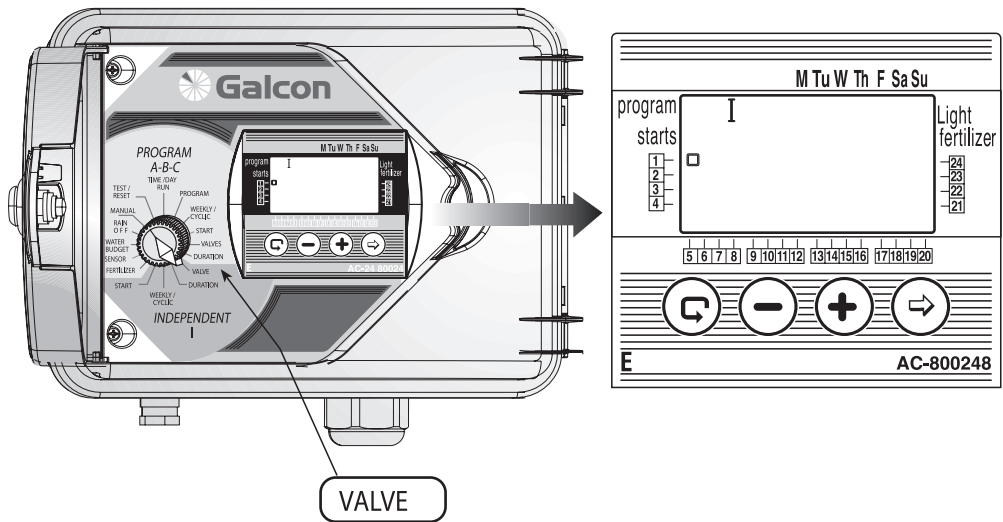

## Controller Programming for Individual Valve - Independent Program I

First select the desired valve and then continue programming the irrigation as follows:

### 1. Valve selecting (Independent Program I)

- Turn selector to **VALVE** mode (in Independent Program I). Symbol I and symbol of first available valve  will appear on display panel. (It is possible to select any valve that has not been pre-designated for another program).
- Press on several times until the symbol  of the desired valve appears.
- Turn selector to irrigation duration.

**The selector should be returned to the TIME/DAY mode following modification or ending of the program.**

# Programming controller for Individual valve - Independent Program I

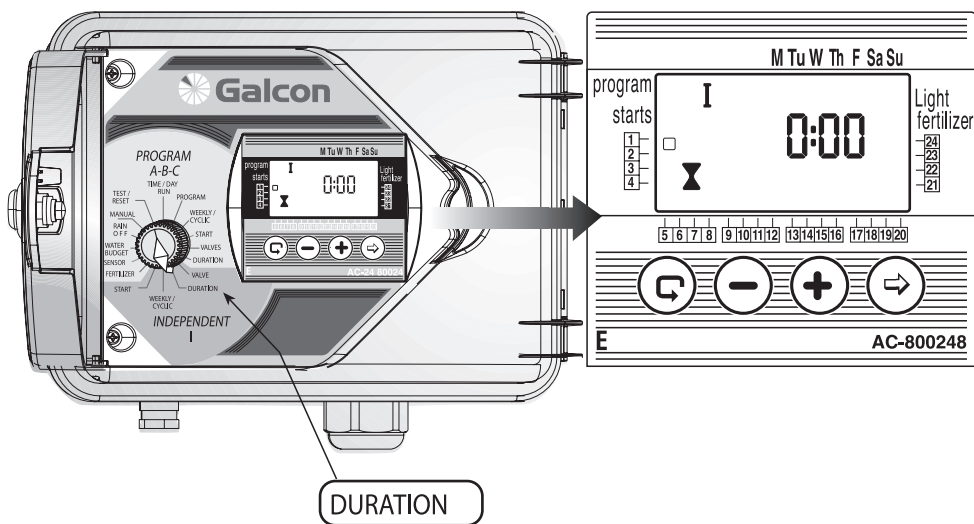

## 2. Setting Irrigation Duration ⌚ I (Independent Program )

It is possible to program irrigation duration for each valve from one minute up to 9 hours (8:59).

- Turn selector to **DURATION** mode (in Independent **I** program).
- The display will show: symbol **I**, duration ⌚, valve  - in line with the selected valve, and hour digits.
- Press on  $\rightarrow$ . The hour digits will blink. Using  $+$  and  $-$  as necessary set the number of desired hours.
- Press on  $\rightarrow$ . The minute digits will blink. Using  $+$  and  $-$  as necessary, set the number of minutes desired.

**ATTENTION !**  
A valve with irrigation time set at 0:00 will not open.

**The selector should be returned to the TIME/DAY mode following modification or ending of the program.**

# Programming controller for Individual valve - Independent Program I

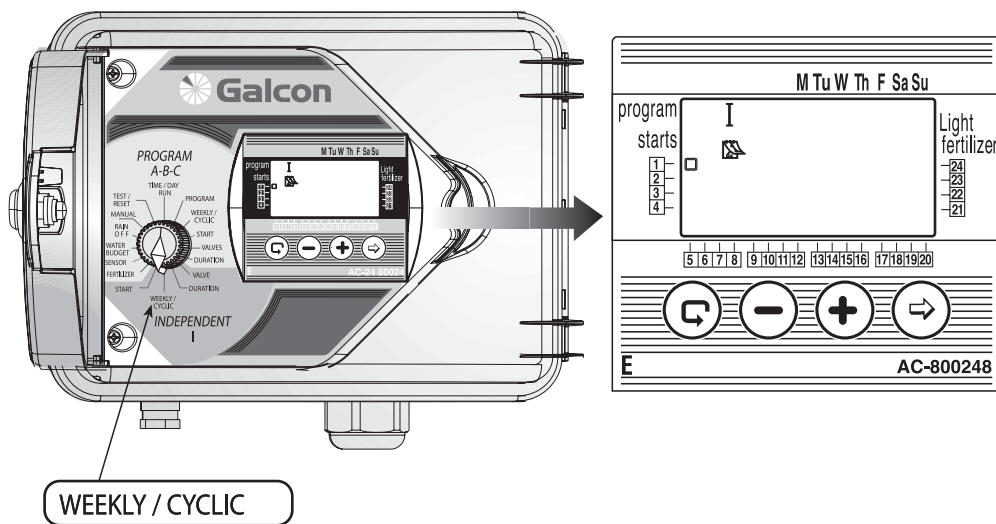

WEEKLY / CYCLIC

## 3. Irrigation by Day of the Week

### Selecting Irrigation Days

- In this operation set the days of the week that the designated valve will operate.
- Turn the selector to **Weekly/Cyclic** mode (Independent Program I).
- Press on and select weekly program .
- Press on . At the top of the display panel a blinking arrow will appear under Monday. If you select Monday as an irrigation day press . The arrow under Tuesday will remain set and stop blinking while the arrow under Monday will begin to blink. If you do not select Monday as an irrigation day press and the arrow will disappear and an arrow under Tuesday will begin blinking (and so forth).





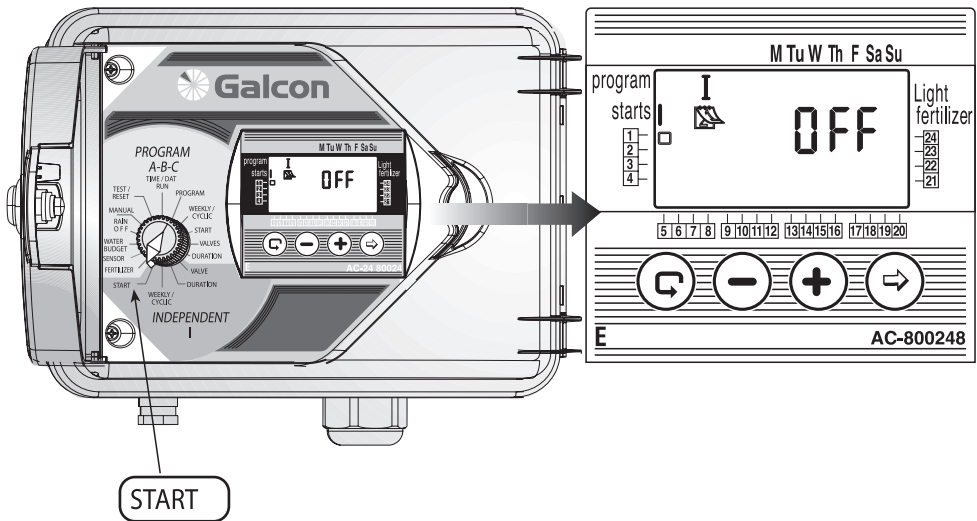



**The selector should be returned to the TIME/DAY mode following modification or ending of the program.**

# Programming controller for Individual valve - Independent Program I



## Starting Irrigation Time for Weekly Program

In this operation it is possible to program up to 4 different starting times for a 24 hour period. The valve will open at these starting times for the designated duration.





- Turn selector to **START** mode (Independent Program I). The display panel will show: **I** starts , the Weekly Program symbol , the word **OFF** or the last entered starting time, valve in line with the selected valve.
- Press on . The data appearing will blink (or the last starting time).
- Set the desired starting time using  and  as necessary. (Note AM/PM designations).
- Repeat Steps 2 and 3 to Program **START** 2, 3, 4 (START II- III-IV) if desired.
- To cancel a specific starting time, select the time with  and press on . The hour digits will blink. Press  or  as necessary until the word **OFF** appears on the display panel.

**The selector should be returned to the TIME/DAY mode following modification or ending of the program.**

## 4. Cyclic Irrigation Programming

In this operation the controller is programmed to operate the selected valve at set cyclic times. The cycle can be set from one day up to 30 days.

### Cycle Time Selection



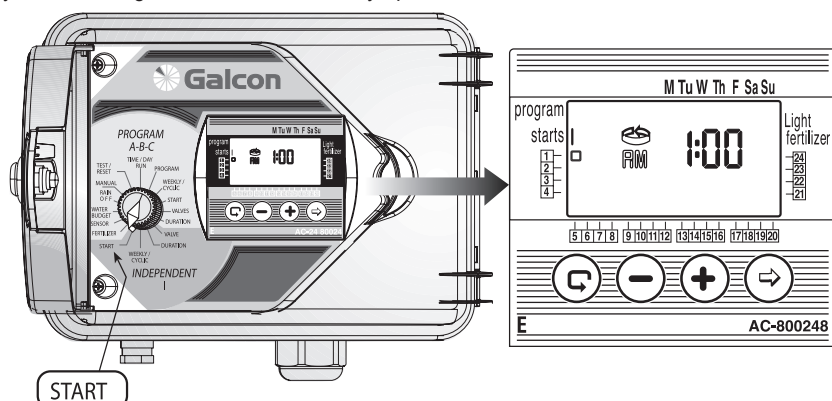





- Turn selector to **WEEKLY/CYCLE** (mode Independent Program I)
- Press on  until  symbol and **DAYS 1** appears, meaning, the cycle is 1 day.
- Press on . 1 blinks.
- Set cycle time using  or  as necessary up to 30 DAYS.



### Starting Irrigation Cycle for Cyclic Programming

In this operation the time and day for starting cyclical irrigation of the first valve is set (in cyclical programming there is only one start time). All of the valves attributed to the designated program will open in sequential order. As the first valve closes, the second will open and so forth.

The number of days preceding the start of the program must be set. 0 DAYS – program will start operation as of that day, 1 DAYS – program will start operation the following day and so forth. Days preceding start of cycle irrigation may be up to 14 days.

- Turn selector to **START IRRIGATION** mode (Programs A, B and C). **START 1**, and the last displayed starting time/OFF will appear on display panel.
- Press on . Hour digits will blink. Set the desired starting time using the  and  buttons as necessary.
- Press on . Minute digits will blink. Set the desired minutes for the starting time using the  and  buttons as necessary.
- Press on  until Number 1 and the word **DAYS** (or the last programmed number of days in cycle) appear on display panel. Set number of days preceding start of cycle with  or  buttons as necessary.

To program additional valves in Independent Program I return to page 21 "Select Valve" (Independent Program I).

**The selector should be returned to the TIME/DAY mode following modification or ending of the program.**

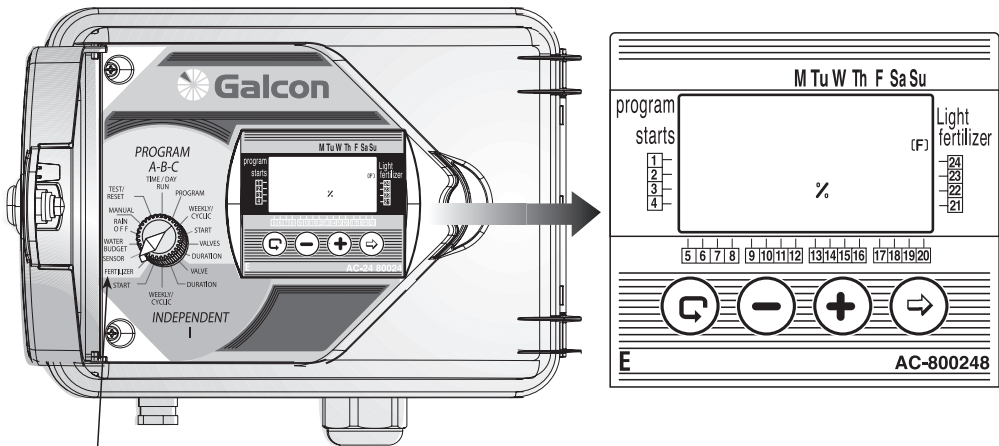

FERTILIZER

## 1. Fertilization Supplement (F)

In the fertilization selection mode the times for fertilization are set for each individual valve.

It is possible to add fertilization prior to irrigation starting times from 10% to 90% of the specific valve duration time. Fertilization will always be given during the valve irrigation .

Example: A specific valve has been programmed for the duration of 60 minutes. Fertilization supplement is set for 20%. Regular irrigation will be operated for the first 24 minutes (without fertilization). Subsequently fertilization will be added for the next 12 minutes (20% of the scheduled time); following fertilization regular irrigation will continue for the next 24 minutes, so the line can be washed.

- Turn selector to Fertilization mode. Symbol of the fertilization valve (F) and % symbol will appear on display panel.
- Press on until the valve you wish to select for your fertilization % supplement blinks on and off.
- 00 will appear on display panel. Press on . 00 will blink. Set the percentage time as desired by using the and buttons as necessary.
- Repeat the above steps for any other valve needed.

**The selector should be returned to the TIME/DAY mode following modification or ending of the program.**

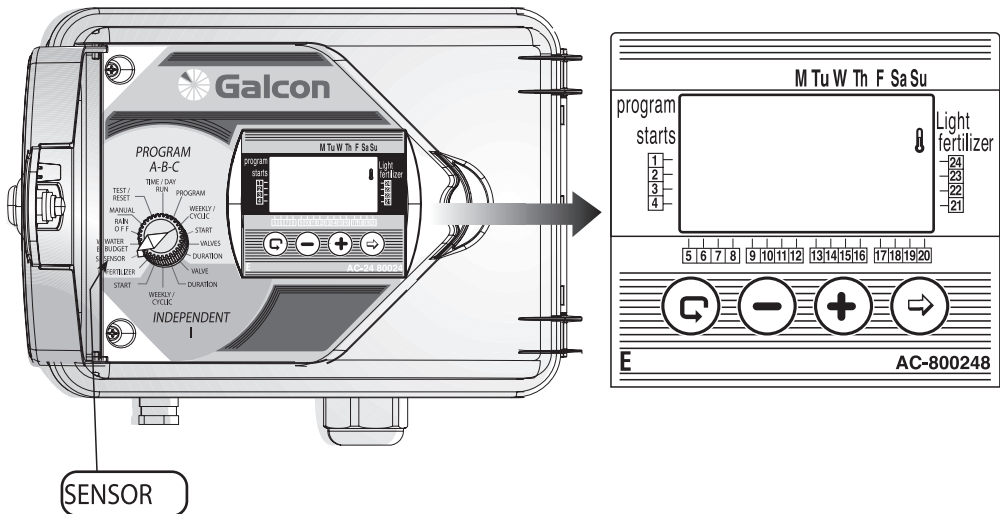

## 2. Attribution of Sensor Valve ¶

The sensor is operated by closing the value to which it is attributed according to relevant conditions, e.g. precipitation, dampness, temperature. An operated sensor will prevent the opening of the valve (or will close it). The operator may select any valve to be attributed to the sensor.

- Turn the selector to the Sensor mode. Sensor symbol ¶ will appear on the display panel.
- Press on (-). The symbol of the first available valve will begin to blink.
- Press on (+) to select valve. The respective valve symbol will stop blinking and symbol of the next available valve will begin to blink.

**ATTENTION!**  
**A valve programmed for 00:00 irrigation duration cannot be attributed to the SENSOR!!!**

**The selector should be returned to the TIME/DAY mode following modification or ending of the program.**

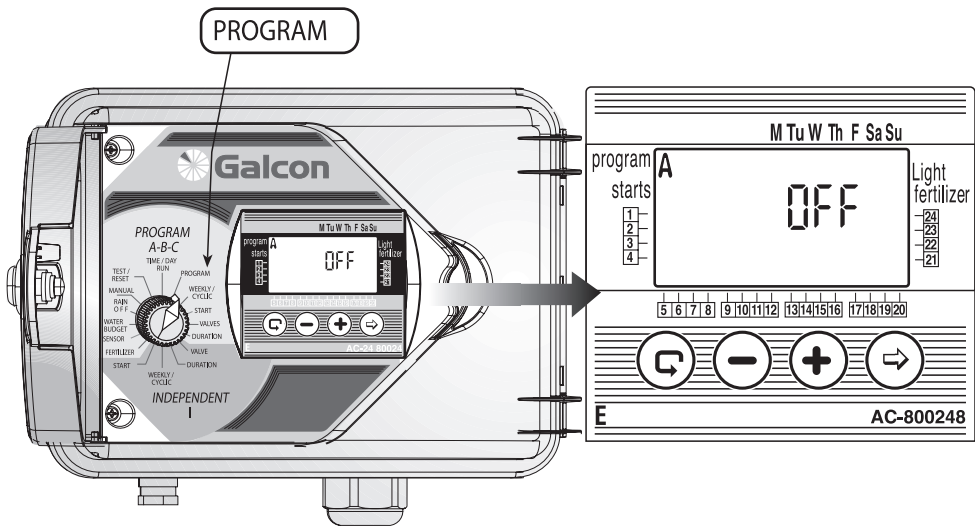

### 3. Garden Lighting Program

It is possible to operate garden lighting only by the weekly irrigation program. Programming the lighting is a separate program operation. The master valve will not open. (Operation of sensor, fertilization supplementation and suspension will not effect lighting operation). Garden lighting operation is adaptable only to relay of 24VAC up to mA 20.

#### 1. Programming Garden Lighting

- Turn selector to Program Selection mode.
- One of the programs will appear on display panel. Press on button until the Light program appears. .
- Press on button. The word OFF will begin to blink. Pressing the button will make the ON button blink. Garden lighting programming has been selected.
- Press button to close program (OFF).
- Continue programming desired data for garden lighting according to instructions of weekly programming on page 16.

**The selector should be returned to the TIME/DAY mode following modification or ending of the program.**

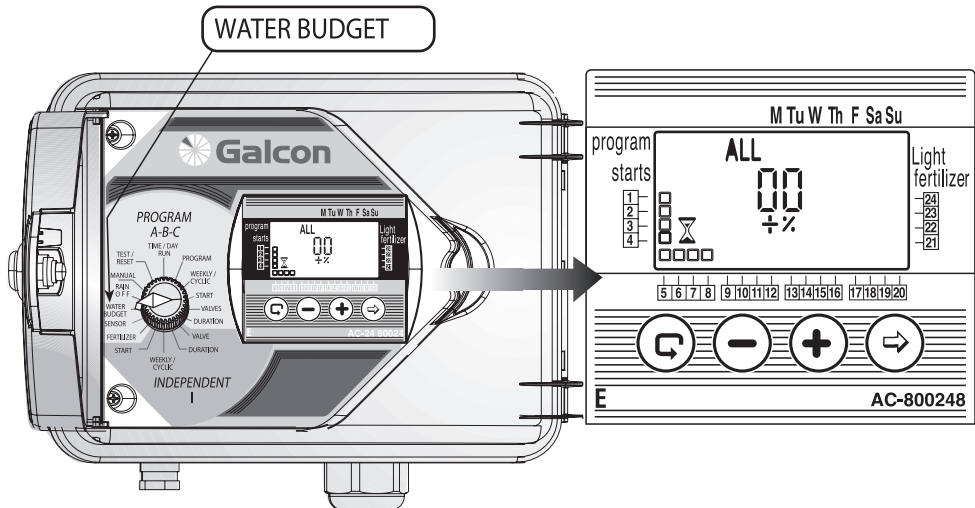

## 4. Irrigation Duration Extended or Shortened by Percentage

The programmed irrigation duration may be extended or shortened for all the valves by specifying a percentage for the duration. This may be inactivated by the following two alternatives:

- Turn selector to % Extend Irrigation mode. 00 + % and the word **ALL**, irrigation duration symbol and symbol of all designated valves will appear on display panel.
- 2. Programming a varying percentage to different valves, according to the respective program A, B and C and Independent Valves I.

### 1. Modifying Percentage for All Valves

- Turn selector to **WATER BUDGET** mode. **ALL, 00, +, %**, duration symbol and symbol ⌘ of all designated valves □ will appear on display panel.
- Press on ⏪. 00 will blink on and off. Set irrigation modification % for all the valves with the ⊕ or the ⊖ button.

**Note!** If percentage modification has been programmed for one of the programs (A,B,C, I) it is not possible to reach ALL mode.

### 2. Modifying Percentage for Irrigation Programs (A,B,C,I)

- Turn selector to % Extend Irrigation mode. 00 + 5 and the word **ALL**, irrigation duration symbol ⌘ and symbol of all designated valves will appear on display panel.
- Press on ⓐ button until Program A and the symbol for all attributed valves to Program A appear on display panel.
- Press on ⏪. 00 will begin to blink. Press ⊕ or ⊖ to increase or decrease the percentage necessary.
- Press on ⓐ button to program the above for Programs B, C and Independent Program I.

**Note!** If percentage modification programming has been set to ALL it is not possible to reach any other programs (Programs A, B, C and I).

**The selector should be returned to the TIME/DAY mode following modification or ending of the program.**

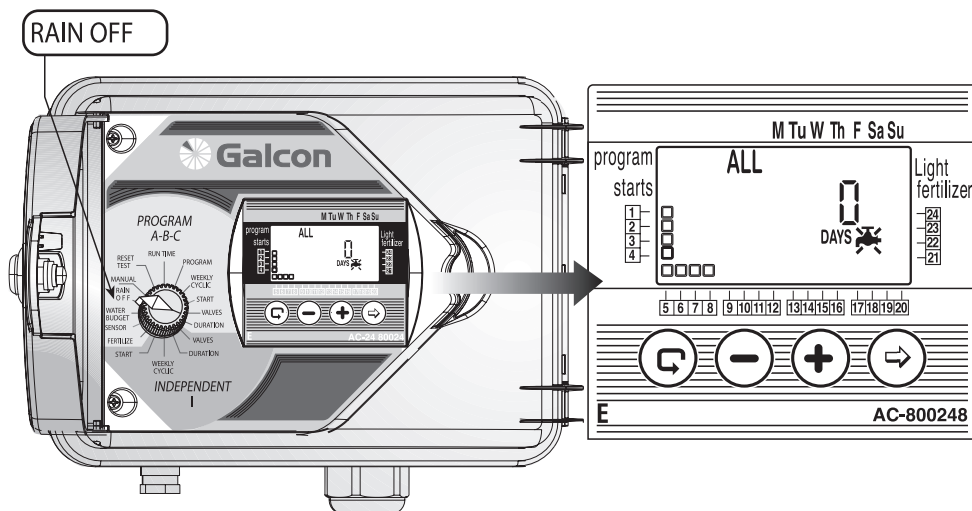

## 5. Suspension- Rain Off ☼

This option is used to temporarily suspend the irrigation controller's control of a number or all of the valves, for example, when it is raining. The irrigation schedule remains stored in the controller but is not implemented.

**In the ALL mode, suspension will disable all of the valves. According to the designation of valve-groups (in Programs A, B, C or I), some rather than all valves may be disabled.**

Suspension may be operated from one day and up to 99 days. At the end of the suspended time, the controller will return to its original schedule as previously programmed.

### 1. Suspension of All Valves

- Turn selector to Suspension mode. ☼, **DAYS 0**, the word **ALL** and valve symbols  will appear on display panel.
- Press on  $\leftarrow$ . **DAYS 0** will begin to blink. Set the number of suspension days necessary for all of the valves using  $\oplus$  and  $\ominus$ .

### 2. Suspension of Valves Attributed to Programs A, B, C or I

- Press on  $\leftarrow$  until Program A and  Symbol of Valves attributed to Program A will appear on display panel.
- Press on  $\leftarrow$ . **DAYS 0** will begin to blink. Set the number of suspension days necessary for all valves attributed to Program using the  $\oplus$  and  $\ominus$ .

**Note!** If valves attributed to one of the programs has already been programmed for suspension, it is not possible to suspend all valves in ALL mode.

The selector should be returned to the TIME/DAY mode following modification or ending of the program.

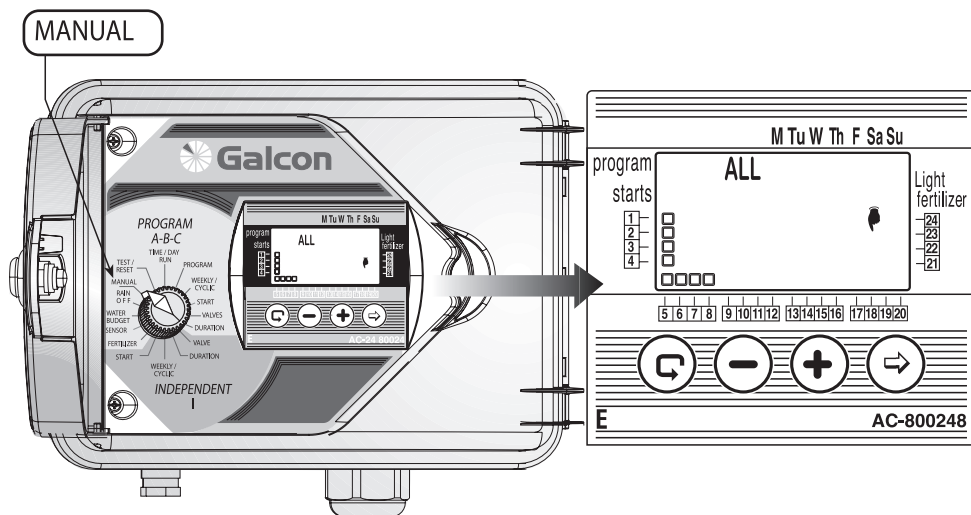

## 6. Manual Computerized Operation

Valves may be manually activated by the following five options:

1. ALL of the valves may be manually operated;
2. Valves attributed to a specific program (A,B,C or I) may be manually operated;
3. More than one program may be manually operated (e.g. A and B);
4. All of the Independent Program I may be manually operated;
5. One or more of the Indep Program I valves may be manually operated.

### 1. Manual Operation of All Valves

- Turn selector to manual mode. Symbol, the word **ALL** and all of the programmed valves  will appear on display panel.
- Press on . The word **HOLD** will immediately appear on the screen for a few seconds.
- The valves will open according to the following sequence: 1. Valves programmed in Independent Program I, from the smallest number upward. 2. Valves attributed to Program A, and then Program B, and the Program C.

### 2. Manual Operation of a Number of Valves Attributed to Programs A, B, C or I

- Press on . programs symbol will blink ON and OFF.
- Press on until the necessary program appears ((for example, Program A). Symbols of the valves attributed to this program along with the symbol will appear on the display panel.
- Press on . The word **HOLD** will immediately appear on the display screen for a few seconds followed by the word **ON**.
- Valves attributed to the designated program will open sequentially.
- Valves attributed to the designated program will open sequentially.

### 3. Manual Operation of one of the Independent Valves

- Press on until I disappears, and the symbol of the first valve attributed to Group I appears on the display panel.
- Using select desired valve.
- To activate selected valve press on . The word **HOLD** will appear on the screen for a few seconds followed by the word **ON**. The selected valve will immediately open.

## 7. Testing

Turn the selector to **TEST/RESET** mode. Serial Testing of the Programmed Valves

- Press simultaneously on  $\ominus$  and the  $\odot$  for 4 seconds. All the programmed valves  $\square$  will appear on the display panel and a drop  $\blacktriangledown$  will appear in line with the first valve – showing that this valve is open.
- Press on  $\oplus$ . The first valve will close and the sequential valve will open.
- If one of the valves is short-circuited the drop  $\blacktriangledown$  in line with the valve will blink. The valve must be detached or the short circuit repaired to enable the testing to be continued.

### Testing of an Individual Valve

- Press on  $\rightarrow$ . The symbols  $\square$  of all the valves will appear, and the symbol of valve 1  $\square$  will blink.
- Using  $\odot$  select the necessary valve needed to be tested (the symbol of the selected valve will blink).
- Press on  $\oplus$ . The selected valve will open and the drop symbol  $\blacktriangledown$  will appear in line with it. Press  $\ominus$ . The valve will close.

**Please Note:** In order to enable the fertilizer valve to be tested, it is necessary to open one of the valves and the main valve (if there is a main valve) manually in order to ascertain a flow of water, and only then may an electrical testing of the fertilizer valve be done.

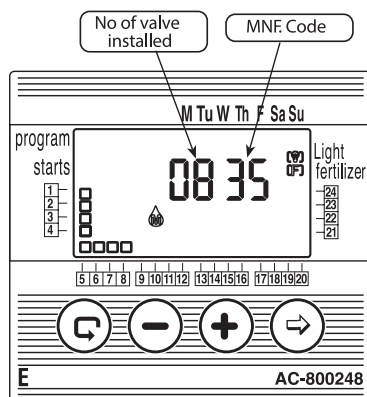
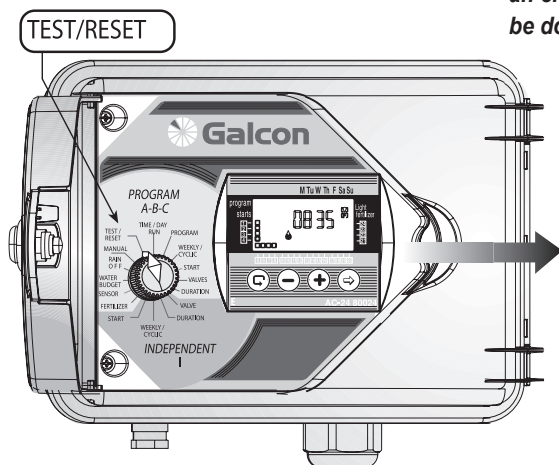

## 8. RESET

It is possible to delete all of the controller's programs.

- Turn the selector to **Test/Reset**.
- Press simultaneously  $\ominus$  on  $\odot$  and for 4 seconds. All of the controller's programs will be deleted. The full display will appear on the screen signifying the deletion of all of the programs. The procedure has been completed successfully. The no. of valves and MNF. code will appear on the screen. The controller must now be reprogrammed.

**The selector should be returned to the TIME/DAY mode following modification or ending of the program.**

## 1. Low Battery Warning

When the battery power is low, a battery icon  will appear on the display panel. The battery should be replaced as soon as possible. The battery serves as a backup power for only for the clock. The program is stored in the memory of controller (up to 20 years!) without any source power.

Note! If power fails when battery is low the clock must be reset. When electrical power is returned, the clock will blink on and off and the programs will operate. The clock blinks to warn the operator that there was a power failure (i.e. state of no electricity and no battery backup), making a replacement of the battery and resetting of the clock necessary.

\* The battery should last for at least one year (alkaline battery).

## 2. No Power Warning

If for any reason electrical power is not reaching the controller  will appear on the display panel.

**ATTENTION!**  
**When there is a loss of electrical power  
the valves will not open but the  
controller will continue as programmed.**

**NOTE!** Controller cannot be programmed when battery is low and there is no electrical power.



## 3. Filter

Filter must be installed in front of controller valve. Cleaning should be done every few months. Troubleshooting may be caused by an unclean filter.

## 4. Water Pressure

- Recommended water pressure: 1 – 6 (bar).

## 5. Troubleshooting - Detection and Repair

| Problem                                                                    | Cause                                         | Repair                                                                                                                                                                                                                                                                                                                                                                                                                                                                                              |
|----------------------------------------------------------------------------|-----------------------------------------------|-----------------------------------------------------------------------------------------------------------------------------------------------------------------------------------------------------------------------------------------------------------------------------------------------------------------------------------------------------------------------------------------------------------------------------------------------------------------------------------------------------|
| Valve will not open in automatic program/<br>Computerized manual operation | Disconnection of valve control cable          | Carefully check wire connections and valve control cable                                                                                                                                                                                                                                                                                                                                                                                                                                            |
| Blinking drop in line with one of the valves on display panel              | Short-circuit in valve control cable/solenoid | Check wire connections/<br>replace solenoid                                                                                                                                                                                                                                                                                                                                                                                                                                                         |
| Controller cannot be programmed/Display does not appear                    | Problem in power circuit and impaired battery | Check power source/<br>transformer or replace battery                                                                                                                                                                                                                                                                                                                                                                                                                                               |
| Sensor icon blinking and valve does not open                               | Short circuited sensor                        | Replace sensor or repair connection                                                                                                                                                                                                                                                                                                                                                                                                                                                                 |
| Valve will not close                                                       | Operating handle on valve in OPEN position    | Turn valve handle to AUTO closed position                                                                                                                                                                                                                                                                                                                                                                                                                                                           |
|                                                                            | Dirt and scale in valve                       | Clean valve                                                                                                                                                                                                                                                                                                                                                                                                                                                                                         |
|                                                                            | Problem in valve (e.g. torn diaphragm)        | Replace valve                                                                                                                                                                                                                                                                                                                                                                                                                                                                                       |
| Faulty controller activity                                                 | Defective Memory                              | * Operate RESET mode:<br>Press  and  simultaneously for 4 seconds. All controller programs will be deleted. On screen display will appear showing the programs that have been deleted. The process has been completed. Number of controller stations and model number will appear on screen. Controller must be reprogrammed. |

- **Note:** This operation will cancel all of the programs previously programmed in the controller.

### Accessories

BSP 3/4" Network Filter

BSP 1 " Network Filter

Spare parts kit

3/4" Valve and 24 VAC solenoid

1" Valve and 24 VAC solenoid

1 1/2" Valve and 24 VAC solenoid

2" valve and 24 VAC solenoid

24 VAC / 230 transformer

2 wire Valve control cable (50 meter roll)

6 wire Valve control cable (50 meter roll)

8 wire Valve cable control (50 meter roll)

10 wire Valve control cable (50 meter roll)

Sensor

4 stationed module

### CUSTOMER SERVICE

Galcon's customer service offers customers instruction. The service may be contacted by telephone at: 04 – 6900200 , Mondays – Thursday between the hours of 8:00 – 13:00.

Repair service is offered through the store at which the instrument was purchased, according to the warranty conditions.

1. Galcon shall, for a limited period of 36 months from the retail purchase date of the original (first) purchaser ("the Warranty Period"), provide limited warranty for the Products, as provided for and subject to the provisions and limitations of this Limited Warranty Certificate.
2. Galcon's Warranty for the Product only extends to the original purchaser of the Product ("the Customer") who, upon requesting warranty service, must present Galcon with a valid purchase receipt. Failure to produce the said documentation will result in the request for warranty being null and void and a waiver of all claims by customer against Galcon.
3. GALCON warrants to the Customer that the Irrigation Control Product ("the product") shall materially conform to the description in Galcon's documentation and shall be free from defects in material and workmanship. Accordingly, Customer's sole and exclusive remedy under this warranty is the repair or – to Galcon's sole discretion – the replacement of the Product or any part/s according to the terms of this Warranty, and no other remedy shall be available. Therefore, if - within the Warranty Period - the Product is proven to be defective by reason of faulty workmanship or materials by Galcon, Galcon undertakes, with reasonable promptness, to have the defective Product (or any part/s thereof) repaired, or at Galcon's discretion, replaced; All subject to the terms and conditions of this Limited Warranty Certificate.
4. Galcon's warranty for the Product or otherwise shall not apply to any of the following: (i) any conduct (by act or omission) not by Galcon, including any misuse/abuse of any Product (or part/s thereof), and/or any failure to install and/or use any Product in full compliance with Galcon's instructions; (ii) other systems/components/devices/technologies and/or the integration/interface thereof with any Product; (iii) any part/component which has been included/installed in any Product not at Galcon's approval and/or other than by Galcon; (iv) any actual or attempted change/repair/interference of/with any Product (including any use/handling of, and/or interference/dealing with, any code of any software included/used in the Product) other than by Galcon; (v) any data/information/content which has been inserted/included in a Product; (vi) malfunction or damage resulting from accidents, which occur during transit and/or handling, and/or malfunction or damage due to fire, earthquake, flood, lightning and/or any other external disaster; (vii) unforeseen accidents, wear and tear, or any other external factors beyond Galcon's reasonable control, or to any Product installed, repaired, adjusted, rebuilt, modified, changed or converted by any person (including the Customer) other than Galcon;
5. In addition and without derogating from the provisions of this Warranty, Galcon's warranty is conditioned upon the all of the following taking place: (i) Customer's operating and maintaining the Product in accordance with Galcon's instructions; (ii) Customer's not being in default of any payment obligation to the Galcon (or its authorized dealer, as relevant).
6. Galcon does not give any warranty or guarantee whatsoever in respect of any Product (or any part/s thereof) which has not been manufactured and distributed by the Galcon and which has not been purchased from the Galcon or any of its authorized dealers, whether such products are branded with any trademarks similar to any trademark belonging to or used by Galcon.

7. After replacement or repair of the Product, the Warranty for the new or repaired Product shall be valid only for the non-expired period of the original Warranty Period. Any defective Products or part/s, which has been replaced, shall become Galcon's property.
8. Galcon reserves the right to charge the Customer if any warranty service is requested and carried out but no fault is found in the Product or if such defect/fault is not under Galcon's Warranty.
9. Notwithstanding anything to the contrary, Galcon shall not be responsible and/or liable, under any circumstances and in any way, for any loss, damage, costs, expenses, expenditures, responsibility and/or liability (including of Customer and/or any third party) – including (without limitation) direct and/or indirect (including incidental and/or special and/or consequential), however arising, including in respect of damages to or loss of property and/or equipment, loss of profit, loss of use, loss of revenue or damages to business or reputation, whether or not based on breach of contract, tort (including negligence), product liability or otherwise - arising from the performance or non-performance of any aspect of the Product or any part thereof; All of the above, whether or not Galcon and/or the Customer shall have been made aware of the possibility of such loss.
10. In any event, any liability which Galcon may have in connection with the Product and/or this Warranty, including (without limitation) in connection with and/or resulting from the Product (or any part thereof) and the use thereof, shall be limited to a total amount (for all damages, claims and causes of action in the aggregate) equal to the consideration actually received by Galcon from the Customer for the Product. The limitations shall apply whether the liability is based on contract, tort, strict liability or any other theory.
11. This Warranty and the remedies set forth herein are exclusive and in lieu of all other warranties, remedies and conditions, whether oral, written, statutory, express or implied. GALCON SPECIFICALLY DISCLAIMS ANY AND ALL STATUTORY OR IMPLIED WARRANTIES, INCLUDING, WITHOUT LIMITATION, WARRANTIES OF MERCHANTABILITY AND FITNESS FOR A PARTICULAR PURPOSE AND WARRANTIES AGAINST HIDDEN OR LATENT DEFECTS.
12. The Customer shall be solely responsible for the selection, use, efficiency and suitability of the Product(s).
13. The provisions of this Limited Warranty Certificate shall be interpreted and governed, solely and exclusively, pursuant to the laws of the State of Israel, and no other law shall apply. Any and all legal actions shall be litigated within the jurisdiction of the courts of Israel, and no other jurisdiction shall apply. Customer waive any objection to such jurisdiction and venue on the basis of it being an inconvenient forum.

B122.03



Kfar-Blum 1215000, Tel. 972-4-690-0222, Fax. 972-4-690-2727  
E - M a i l : [info@galconc.com](mailto:info@galconc.com), [www.galconc.com](http://www.galconc.com)